

Appendix A

Parameter Lists

Table A.1: TESLA 500 – TTFL parameter comparison.

Parameter	TESLA 500	TTFL	
Linac Energy	250 GeV	500 MeV	
RF frequency	1.3 GHz	1.3 GHz	
Accel Gradient	25 MeV/m	15 MeV/m	
Q_0	5×10^9	3×10^9	
# Cryo modules	≈ 2500	4	
Energy spread, single bunch	1.5×10^{-3}	$\approx 10^{-3}$	
Energy variation, bunch to bunch	10^{-3}	$\approx 5 \times 10^{-3}$	
Bunch length rms	1 mm	1 mm	
Beam current	8 mA	8 mA	
Beam macro pulse length	0.8 ms	0.8 ms	
Lattice β typical	$\langle 66 \text{ m} \rangle$	12 m max	
		Inj I	Inj II
Injection Energy	10 GeV	10 MeV	20 MeV
Emittances (x/y), $\gamma\sigma^2/\beta$	20/1 μm	$\approx 5 \mu\text{m}$	$\approx 20 \mu\text{m}$
Beam size σ , end of linac	50/12 μm	250 μm	500 μm
Beam size σ , injection	260/60 μm	1.7 mm	3.5 mm
Bunch frequency	1 MHz	217 MHz	1 MHz
Bunch separation	1 μsec	4.6 ns	1 μsec
Particles per bunch	5×10^{10}	2.3×10^8	5×10^{10}

Table A.2: Injector I

Gun Energy	250	keV
Output Energy	9.9	MeV
Accel Gradient (Capture Cav)	10	MV/m
Frequency Capture Cav	1300	Mhz
Phase spread, gun	± 150	deg
Prebuncher Frequency	216.7	MHz
Bunch Population	2.3×10^8	per bunch
RMS Phase Width	0.77	deg
Total Phase Width	3.2	deg
RMS Energy Spread	0.078	MeV
Total Energy Spread	0.3	MeV
Emittance ($4\gamma\sigma^2/\beta$)	16.8	mm-mrad
RMS bunch length	0.49	mm
$\Delta E/E$ RMS	0.8	%

Table A.3: Injector II: RF photoemission gun and accelerating section.

Bunch spacing	1	μsec
Bunches per macropulse	800	
Electrons per bunch	5×10^{10}	
Brightness	4.8×10^{12}	A/m^2
Emittance, $\gamma\sigma^2/\beta$	20	$\text{mm}\text{-mrad}$
RF frequency	1.3	GHz
RF power—gun	4.5	MW
Solenoid focusing field on axis	0.14	T
Beam radius at cathode	3	mm
Bunch length, σ before compression	3.1	mm
Bunch length, σ after compression	1	mm
Post gun energy	6	MeV
Injector output energy	20	MeV
Momentum spread	8	$\%$
Longitudinal emittance	1.5	$\text{MeV}\text{-deg}$
<i>Laser pulse FWHM</i>	28	ps
Photocathode QE	1	$\%$
Micropulse energy	> 5	μJ
Time jitter	< 1	ps
Amplitude jitter	< 5	$\%$
Pointing stability	< 100	μrad
Laser wavelength	< 300	nm

Table A.4: RF cavity parameters for the TTFL

Frequency	1.3	GHz
Cells per cavity	9	
Cavity length	1.035	m
Iris radius	35	mm
R/Q	973	ohms/m
E_{peak}/E_{acc}	≈ 2.0	
RF power @ 25 MeV/m	206	kW/m
HOM $k_{long}/cavity$	8.5	V/pC (1mm bunch σ)
HOM $k_{trans}/cavity$	18	V/pC/m

Table A.5: Summary of the cryogenic system heat budget.

	Static Losses	Total Losses 15 MV/m $Q=3 \times 10^9$	Total Losses 25 MV/m $Q=5 \times 10^9$
Summary—2 K			
2 K load, W/m	0.23	1.28	1.78
Budget, 5 modules, W	21	115	160
Summary—4.5 K			
4.5 K load, W/m	1.16	1.27	1.33
Budget, 5 modules, W	104	114	120
Summary—70 K			
70 K load, W/m	6.4	10.4	11.3
Budget, 5 modules	576	936	1017
w/o HOM	576	684	765

Table A.6: Parameters of TESLA 500 and TESLA 1000 as of Jan 95. (Parameters are under evaluation at time of printing.) Items marked with a dagger (\dagger) are analytical results, while items marked with a double-dagger (\ddagger) are the results of simulations carried out by Schulte. N^* is number of electrons (or positrons) per crossing, produced with $p_t > 20$ MeV/c and angle > 0.15 rad.

Parameter	Units	Values	Values
(unchanged values from previous column not filled in)			
		TESLA 500	TESLA 1000
LINAC-Primary Parameters			
Energy (CM)	GeV	500	1000
Energy-Linac	GeV	250	500
N_b	10^{10}	5.14	.91
f_c	kHz	8	20.9
Rep Rate	Hz	10	5
# bunches/pulse		800	4180
bunch separation	μ sec	1.0	0.2
Beam pulse	ms	0.8	0.836
$\epsilon_{n,x}$	$m \times 10^{-8}$	2000	520
$\epsilon_{n,y}$	$m \times 10^{-8}$	100	6.3
σ_z	mm	1	0.5

Parameter	Units	Values	Values
(unchanged values from previous column not filled in)			
		TESLA 500	TESLA 1000
Final Focus System			
σ_x^*	nm	1000	325
σ_y^*	nm	64	8
β_x^*	mm	24.5	20
β_y^*	mm	2	1
L_o -nominal	$10^{33} \text{ cm}^{-2}\text{sec}^{-1}$	2.6	5.3
R		15.6	41
D_x		0.54†	0.24
D_y		8.5†	9.8
H		2.3‡	1.9‡
L with pinch	$10^{33} \text{ cm}^{-2}\text{sec}^{-1}$	5.9	10.4
Υ		0.03‡	0.058‡
δE_{beam}	% av	3.1‡	2.7‡
Cross angle	mrad	0	
N_γ	/beam e	2.5‡	1.3‡
N^*	/crossing	14.5‡	4.5†
LINAC-Secondary Parameters			
Gradient	MV/m	25	
RF freq	GHz	1.3	
2 linac RF length	km	20	40
cavity length	m	1.04	
2 linac # cavities		19328	38656
2 linac # klystrons		604	1208
# cavities/kly		32	32
Kly peak power req	MW	6.85	6.06
Kly pulse length	μsec	1.33	1.37
a/wave length		0.15	
P_b -beam power/beam	MW	16.5	15.2
P_{ac} -2 linac AC power	MW	155	170
P_{ac} -cryo	MW	58	79
P_{ac} -RF	MW	97	91
Damping Ring Energy	GeV	4.0	

Appendix B

Device Coordinates

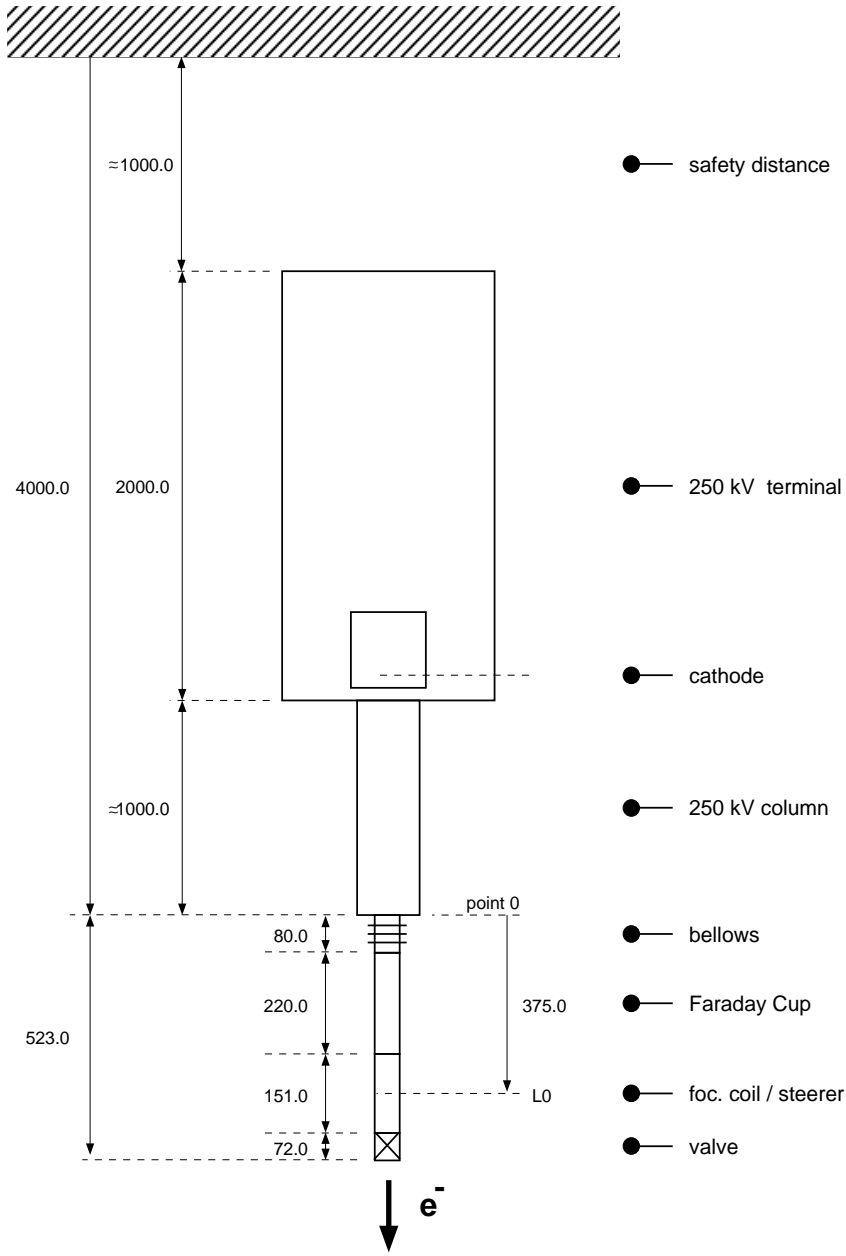

gun section (20.12.94)

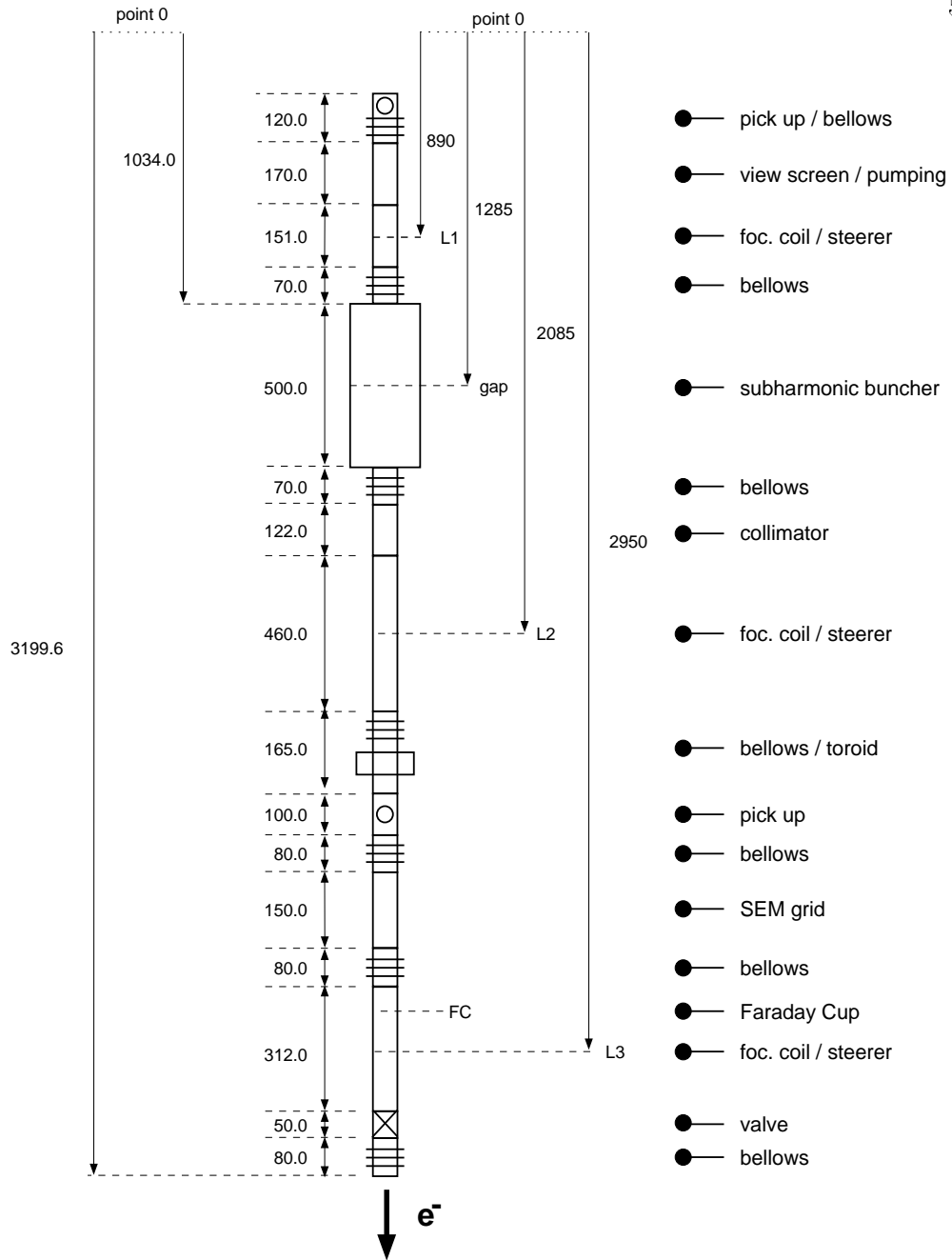

injector section 200 (20.12.94)

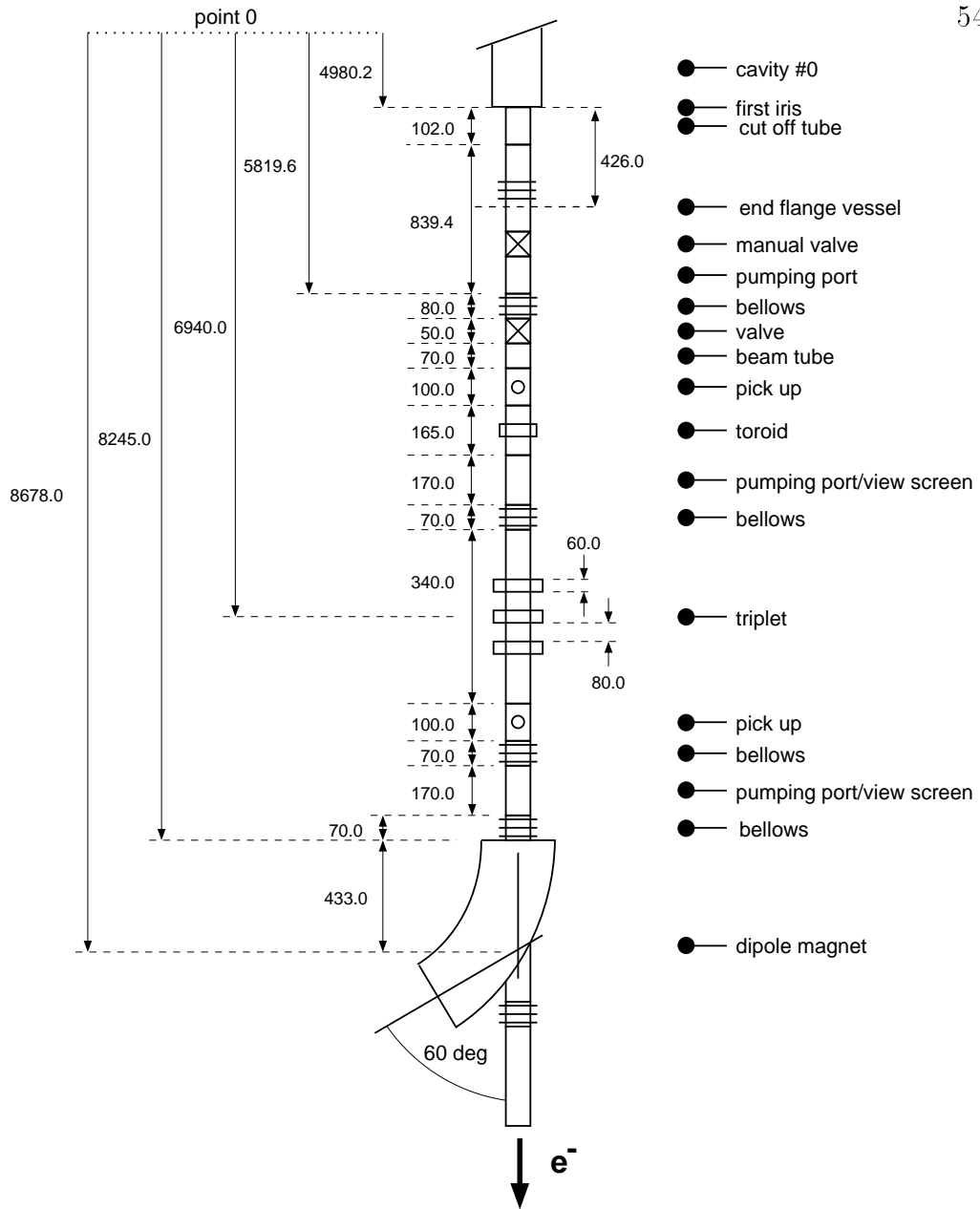

matching section between cavity #0 and dipole magnet (20.12.94)

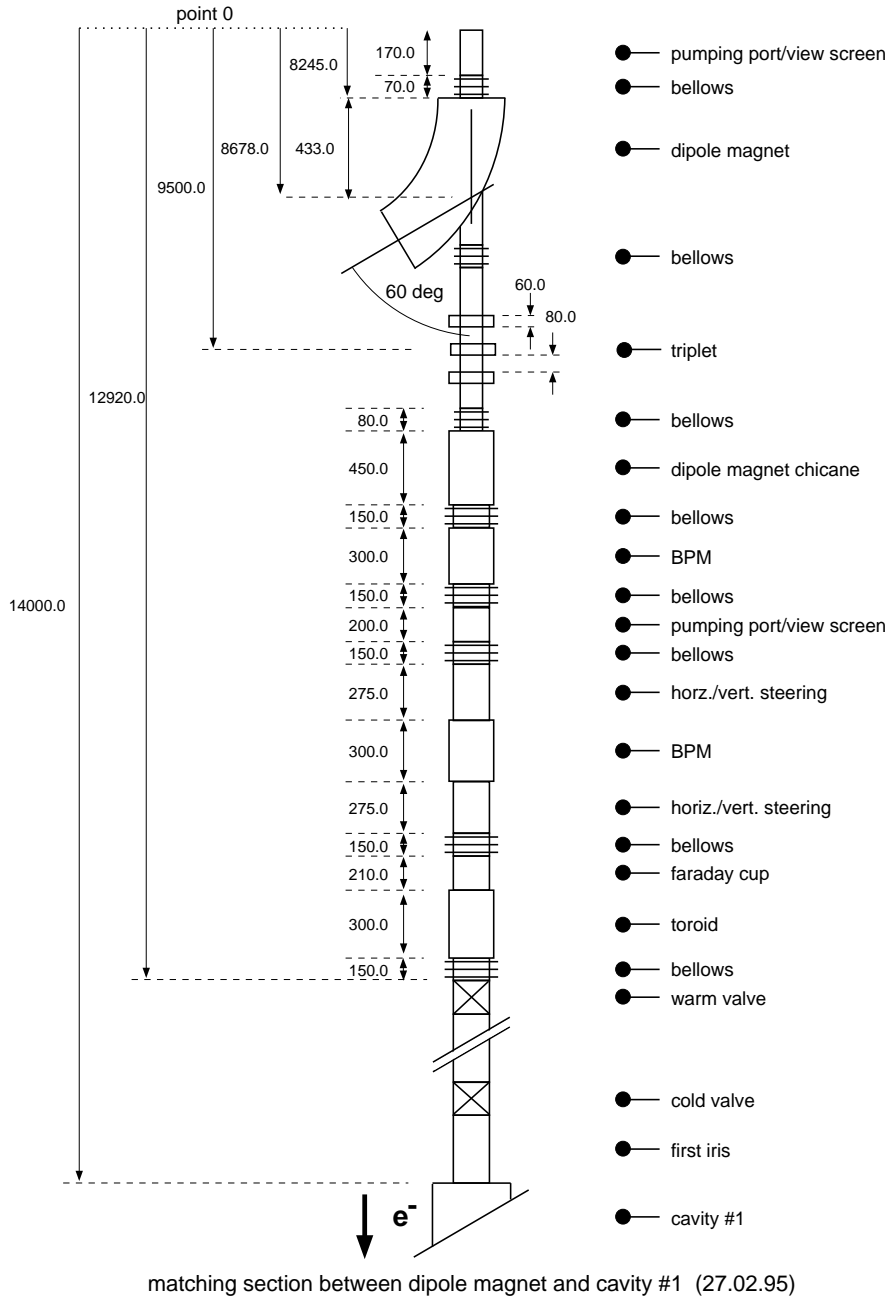

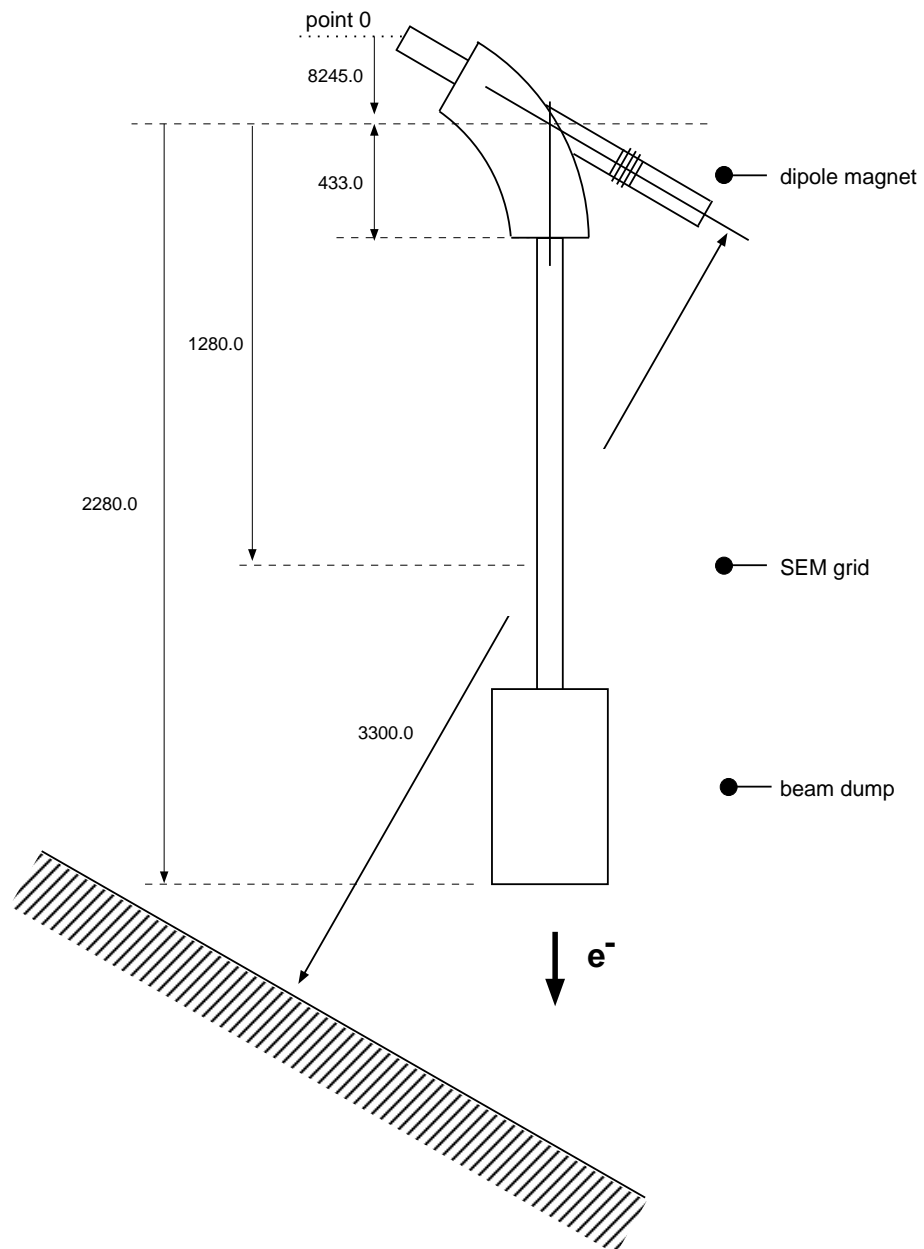

10 MeV dispersive section between dipole magnet and beam dump (20.12.94)

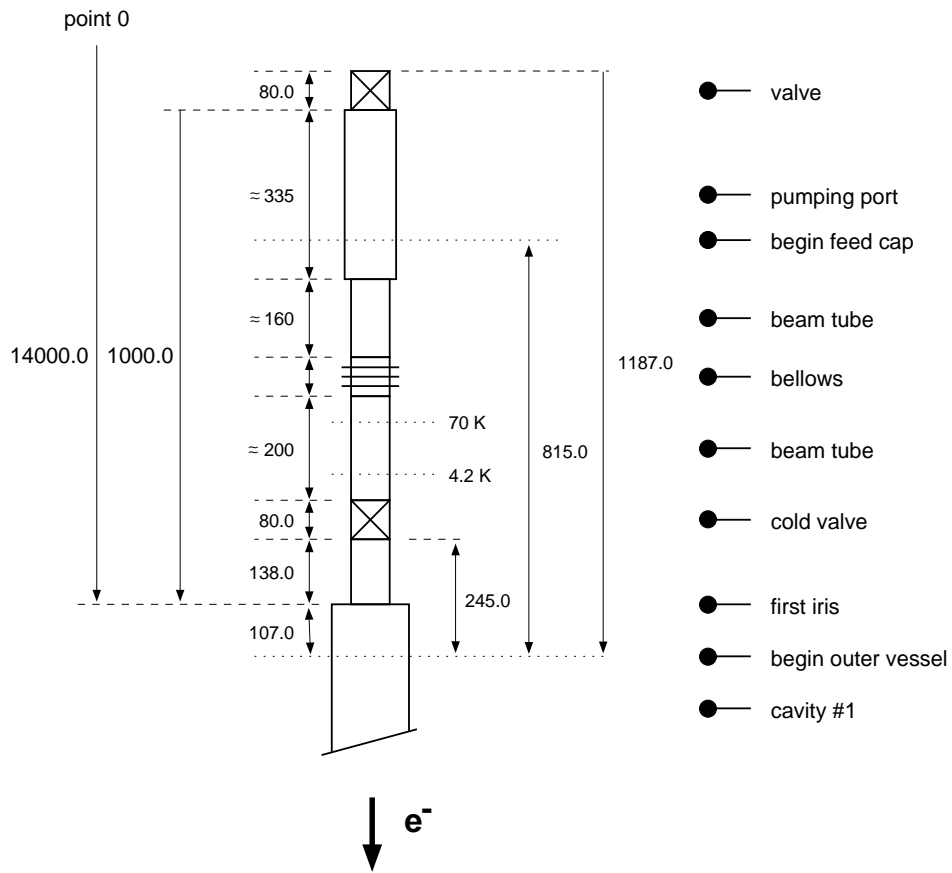

upstream end of cryo module (20.12.94)

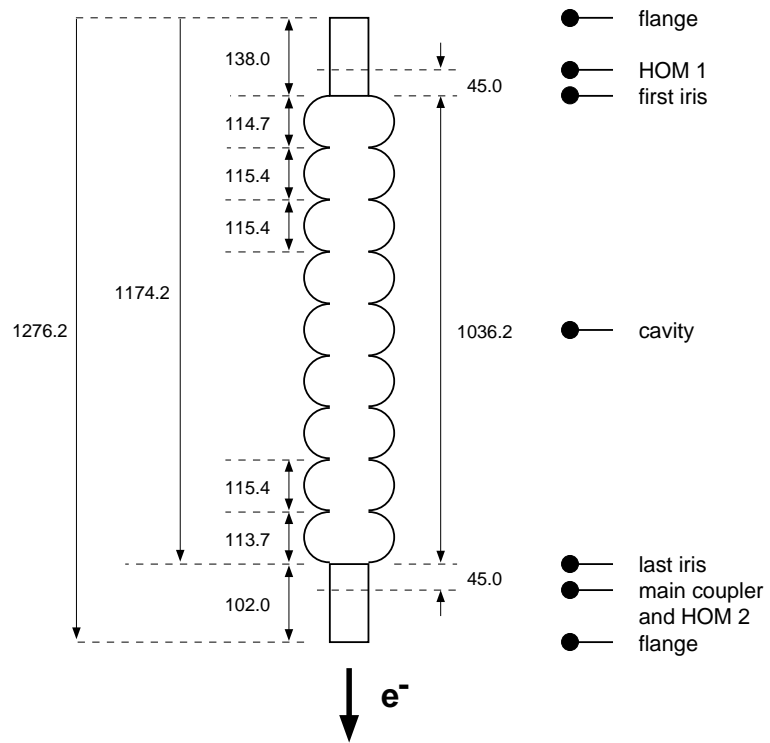

s.c. cavity TTF linac (20.12.94)

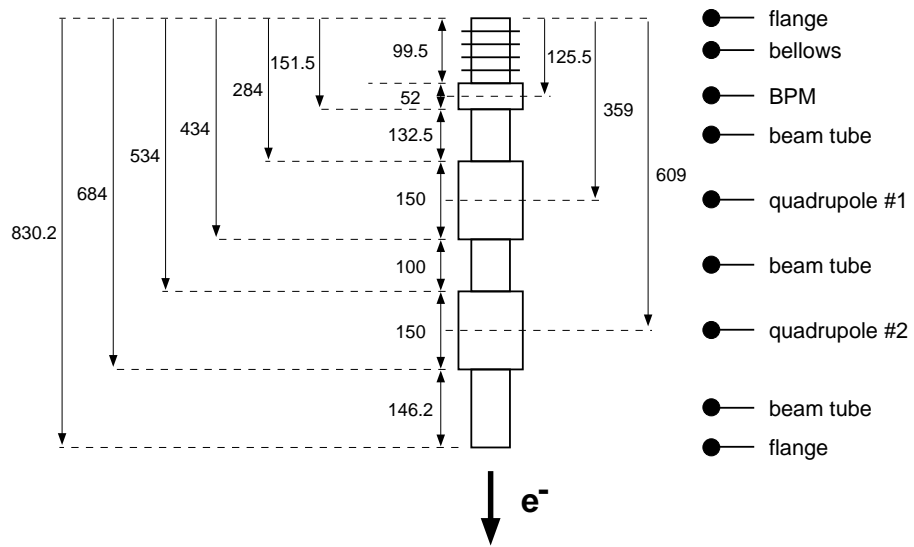

quadrupole module TTF linac (07.09.94)

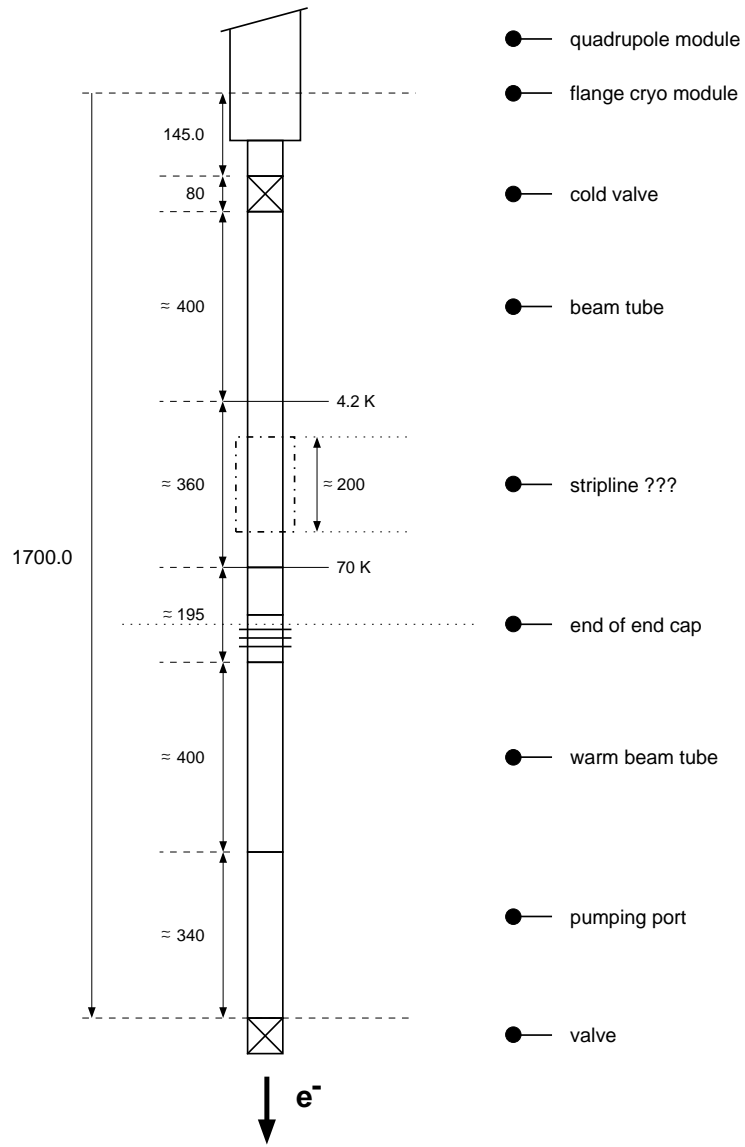

downstream end of cryo module (20.12.94)

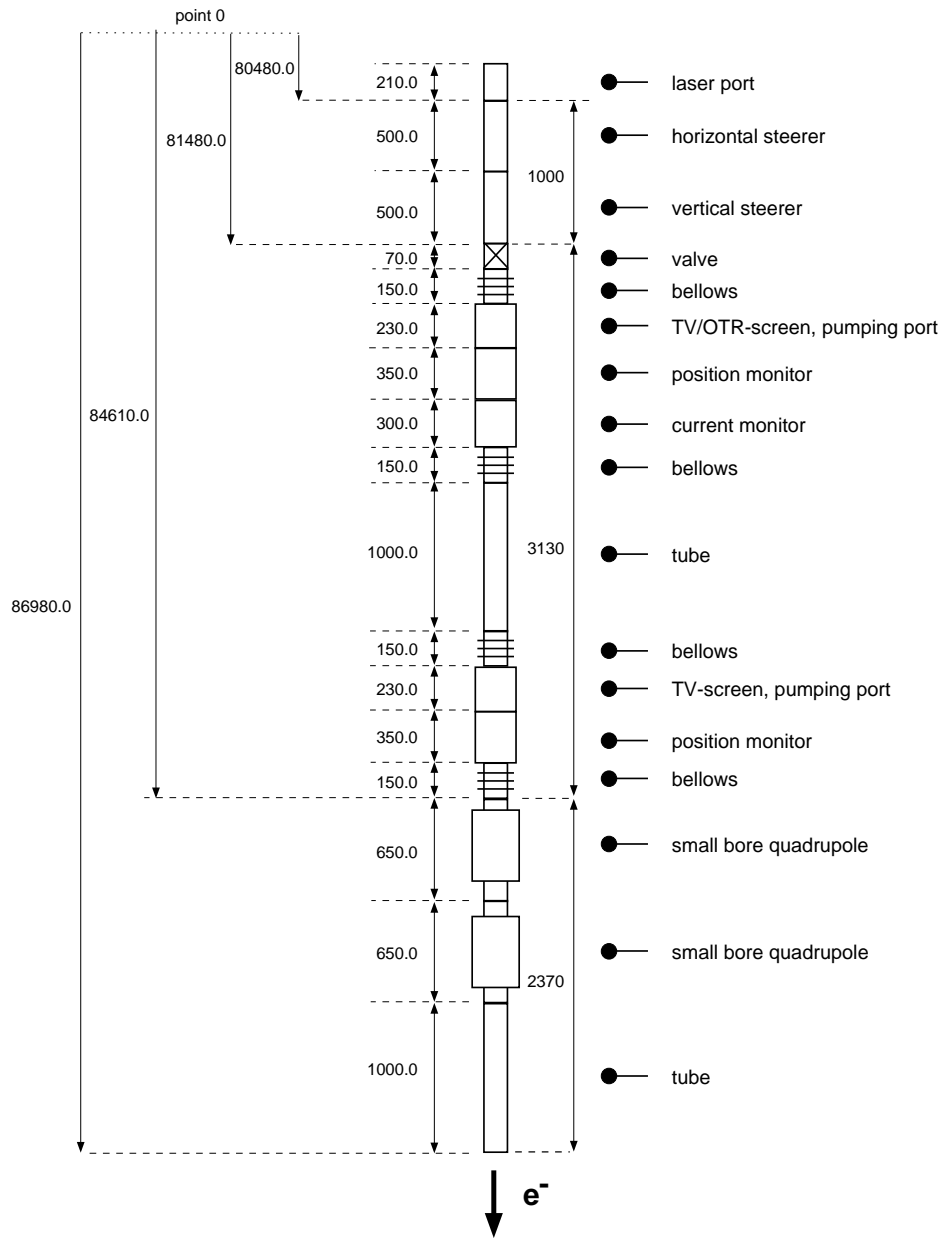

experimental area 1-1 (13.02.95)

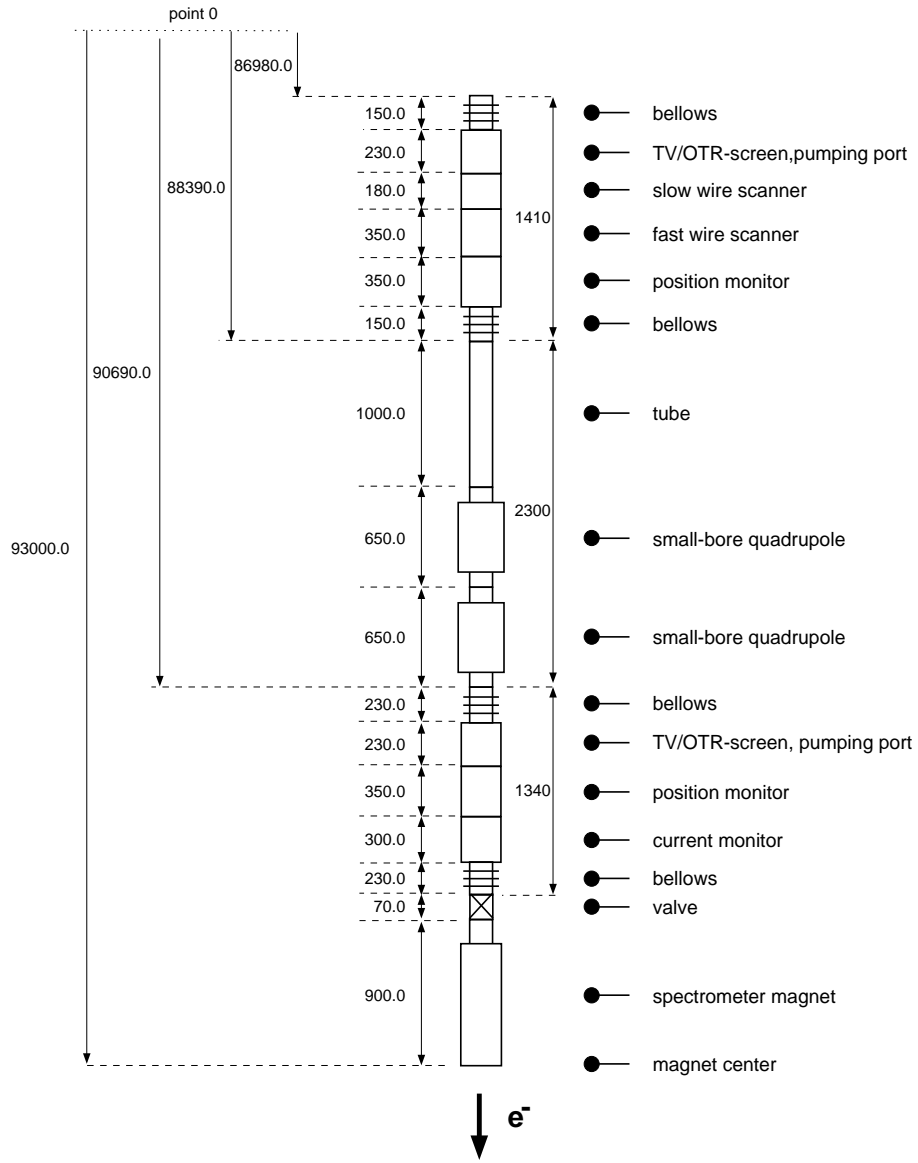

experimental area 1- 2 (20.12.94)

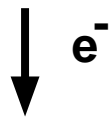
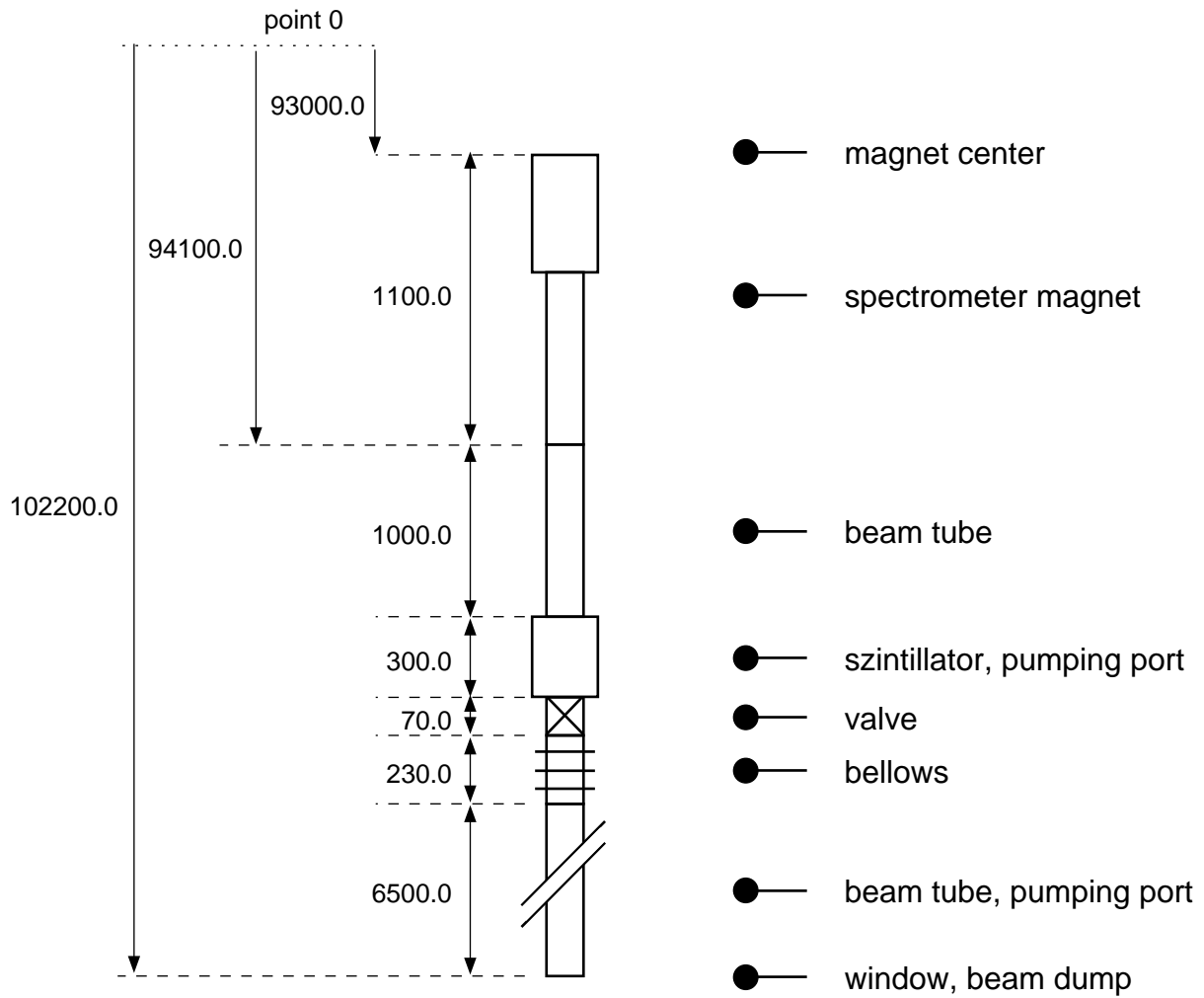

experimental area 2 (13.02.95)

