

COMMISSIONING OF AN ELECTRO-OPTIC ELECTRON BUNCH LENGTH MONITOR AT FLASH

Jonas Breunlin, University of Hamburg, Hamburg, Germany

Bernhard Schmidt, Bernd Steffen, Laurens-Georg Wissmann, DESY, Hamburg, Germany

Abstract

The free electron laser in Hamburg (FLASH) underwent major modifications during a 6 months shutdown like the installation of a 3rd harmonic module, a seeding experiment (sFLASH) and a 7th accelerating module. Also instrumentation has been improved. A new compact electro-optic (EO) bunch length monitor has been installed downstream the first bunch compressor. At this position, the bunches are expected to have a length of about 1 ps, well suited for the resolution of an EO bunch length monitor with spectral decoding of the time (EO-SD). The setup uses a commercial ytterbium fiber laser, a compact optics inside the beam pipe designed at PSI (Switzerland) and a spectrometer with fast InGaAs line scan camera. These components, together with RF synchronisation unit and readout electronics, will be installed in the accelerator tunnel. Reliability, robustness and high uptime are key features as the EO monitor is meant to serve as permanent beam diagnostics. Here we report on the commissioning of the components and first experiments with the complete system.

INTRODUCTION

Free electron lasers (FEL), consisting of a linear electron accelerator and an undulator section are powerful devices for producing very short pulses of light in a wide wavelength range. FLASH is a SASE-FEL in the soft x-ray region. Electron beam parameters like a low emittance and high peak charge densities achieved by a strong bunch compression are required for an efficient SASE process. Measuring the longitudinal bunch shape can be done either destructively by a transverse deflecting structure (TDS) or non-destructively by EO experiments. In the last years several EO measurements have been done at FLASH at 140 meters and still are done [1]. The EO setup described in this paper is installed downstream the first bunch compressor. It's characteristics are a compact design and a high reliability.

EXPERIMENTAL SETUP

The setup consists of a ytterbium-doped fiber laser system with pre-amplifier, an optical gate and a spectrometer with camera. These components in addition to RF synchronization electronics are installed in the FLASH accelerator tunnel behind the first bunch compressor. The setup is radiation-protected by a lead shielding. The EO monitor, a compact box containing the EO crystal and further optics is flanged to the electron beam pipe (see Fig. 1). Because there is no accessibility during accelerator operation,

the deployment inside the accelerator tunnel necessitates a high robustness of all components. A packaged laser system and fiber optics instead of free-space optics make the system less dust-prone. All system parameters can be accessed via remote control.

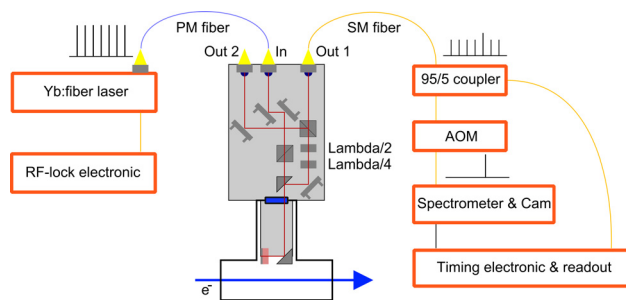

Figure 1: Experimental setup.

Laser System

The utilized laser system is a ytterbium doped fiber laser with a central wavelength of 1030 nm from Menlo Systems. It mainly consists of an oscillator and a pre-amplifier. The oscillator is a stretched-pulse laser with self-starting mode lock from nonlinear polarization evolution. It is custom made for this experiment to fulfill requirements such as a repetition rate of 108 MHz which is the 12th subharmonic of 1.3 GHz, the driving frequency of the accelerating cavities at FLASH. In order to synchronize the laser to an external RF the oscillator length of the oscillator i.e. its frequency must be adjustable. For that purpose a motorized delay stage for coarse and a piezo fiber stretcher for fine adjustments are installed. Furthermore the free-running oscillator should have an integrated timing jitter below 50 fs (1 kHz to 10 MHz).

The laser pulses from the ytterbium-doped pre-amplifier have a pulse energy about 2 nJ and are led through a single-mode fiber to the EO monitor. Here the interaction of the electron bunch's THz field and the chirped laser pulse takes place in an EO crystal. The linear chirp caused by normal dispersion in the fiber pre-amplifier and the attached SM patch cord is crucial for spectral decoding.

RF Synchronization

The laser has to be synchronized to the local RF master oscillator (MO) of the accelerator to establish a temporal overlap of the laser pulse and the electron bunch. The laser comes with a monitor port that is fiber-coupled to the oscillator. A photo diode is connected to it delivering an

RF signal whose 12th harmonic is filtered out by a band pass filter and mixed with an 1.3 GHz signal from the MO (see Fig. 2). The difference frequency is led through a low-pass filter and digitized by a fast sampling ADC. A program running on a digital signal processor (DSP) calculates a regulation signal from the incoming error signal and outputs it to a DAC. This regulation signal, amplified by a piezo driver causes a change of length in a piezo fiber stretcher inside the oscillator. With a deviation of about 6 μm the piezo stretcher is utilized for fast but fine frequency adaptation. Larger drifts are automatically compensated by a motorized delay stage, also driven by a digital regulation. As per description the laser with its 108 MHz repetition rate is locked to the 1.3 GHz reference frequency, there are 12 possible buckets the laser can be locked in. A slow phase detector (AD8302) is used for bucket detection. It compares a 108 MHz signal generated by a photo diode inside the oscillator and a reference signal also coming from the MO.

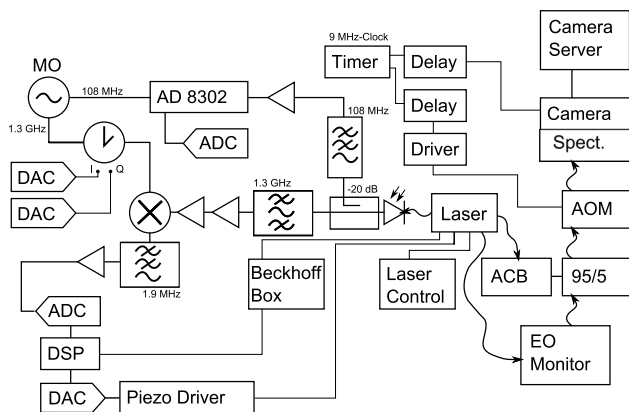

Figure 2: Experimental setup with schematic plan of RF synchronization.

EO Monitor

The electro-optic crystal and further optics are combined in a rugged box next to the electron beam pipe. This EO monitor was designed exclusively for EO-SD experiments at PSI (Switzerland) [2]. Optical alignment is necessary just in commissioning phase. The monitor's design allows a relative movement of the EO crystal to the electron beam without varying the optical path. The short dimensions of approx. 150 mm in electron beam line direction makes an assembly at the beam pipe possible where space is rare. A gallium phosphide crystal with a thickness of 0.5 mm is installed as EO crystal.

Gating, Spectrometer and Camera

As in EO-SD the charge distribution of the electron bunch is coded in the spectrum of the laser pulses, a spectrometer (Shamrock SR-163) and an InGaAs line scan camera (Andor Idus DU490A-1.7) are needed for detection.

The spectrometer can be equipped with an 600 or an 1200 lines per mm grating. This guarantees a good matching between the cameras 512 pixel line array and the laser's spectral bandwidth.

At FLASH the macro-pulse repetition rate is 10 Hz. A macro-pulse consists of up to 80 micro-pulses with gaps of 1 μs or multiples. At 1 MHz micro-bunch repetition rate and an established overlap of electron bunch and laser pulse, every 108th laser pulse is modulated. Since the utilized camera has an acquisition time considerably above 1 μs the pulse train is gated down to 10 Hz by an acousto-optic modulator (AOM).

In parallel to the slow camera readout, the ungated 108 MHz optical pulse train is sampled with a fast photo diode and an ADC to automatically detect the modulated pulses and adjust the laser - electron bunch overlap (see Fig. 1). The overlap adjustment is done by scanning the laser pulse with respect to the electron bunch, accomplished by a vector modulator changing the phase of the reference frequency (see Fig. 2).

MEASUREMENTS

Pulse Length and Optical Spectrum

Laser pulses delivered by the pre-amplifier are measured to have a linear chirp of about 4 ps. As the laser pulses travel through fiber even more linear chirp is added. Figure 3 shows the autocorrelation function (ACF) of such pulses, measured after 2 meters of glass fiber. For a Gaussian time profile, the autocorrelation width is $\sqrt{2}$ longer than the length of the laser pulse which yields a chirped pulse length of 7.2 ps for laser pulses after passing 2 meters of glass fiber. This measurement has been done with the same fiber type and length that in future will connect the laser system to the EO monitor.

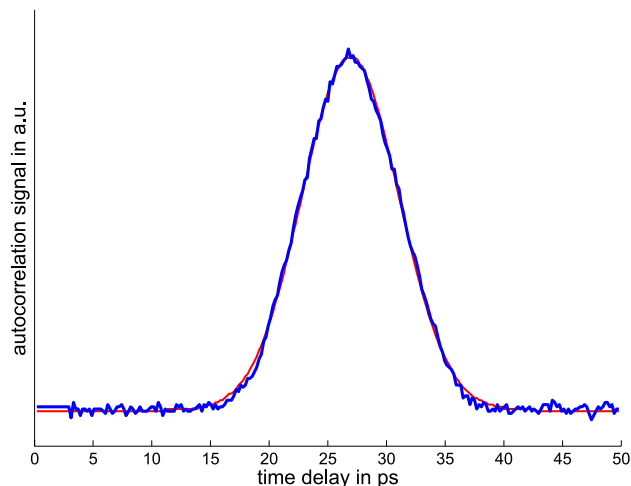

Figure 3: Auto correlating function of laser pulses (blue) and Gaussian fit (red) FWHM width of 10.16 ps.

This linear chirp outweighs non-linear chirp effects which guarantees the linearity between wavelength and time coordinate inside the laser pulse what is crucial for EO-SD. Furthermore the measured laser pulse length is considerably longer than the expected electron bunch length at the experiment's location behind the first bunch compressor.

A high spectral bandwidth is needed in EO-SD experiments as the electron bunch's charge distribution is coded in the spectrum. In Figure 4 the optical spectrum of the pre-amplified laser, measured with an optical spectrum analyzer, is shown. The usable bandwidth is approximated to be about 50 nm.

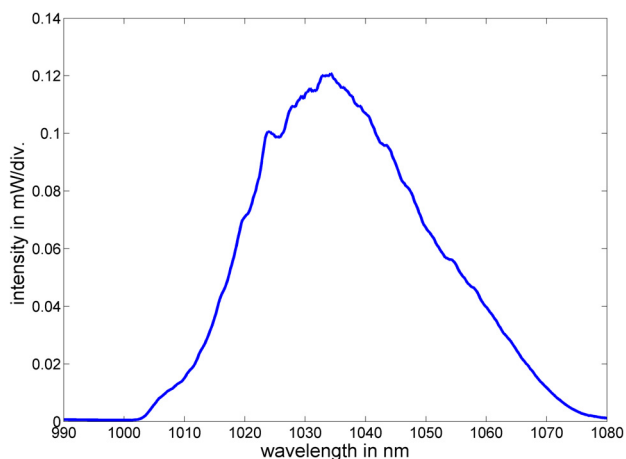

Figure 4: Optical spectrum of pre-amplified laser pulses.

Phase Noise

Phase noise measurements are an important indicator for the correct mode lock state as well as the quality of the RF synchronization. Measurements are performed out-of-loop with a 10 GHz photo diode connected to the pre-amplifier and an Agilent E5052 signal source analyzer with a band pass filter, picking the 1.3 GHz component (12th harmonic). Figure 5 a shows the SSB phase noise and integrated timing jitter of the free-running laser plotted over an offset frequency range of 10 Hz to 10 MHz. The integrated timing jitter from 1 kHz to 10 MHz was measured to be 24.5 fs (restricted by the photo diode) which is in this frequency range lower than the reference's timing jitter. In the frequency range above 1 kHz phase noise should be low because it can't be corrected by the regulation.

The upper cut-off frequency of the utilized regulation is about 1 kHz. Establishing the RF synchronisation the laser benefits from the reference's low timing jitter below 1 kHz (Fig. 5 b). With the regulation running drifts of the laser relative to the reference are automatically compensated. This guarantees a long-time RF synchronization stability (see fig. 6).

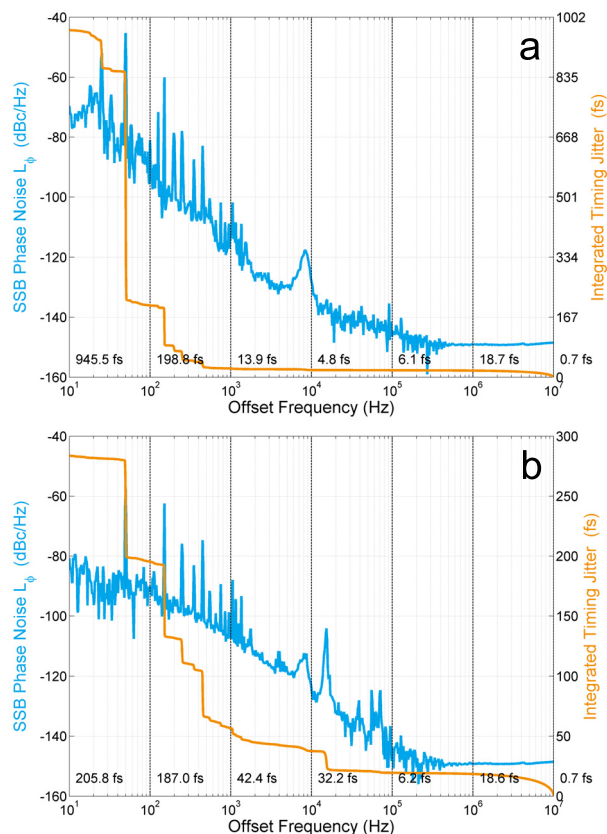

Figure 5: Phase noise and integrated timing jitter with regulation off (a) and regulation on (b).

Long-time RF Synchronization Stability

To be a reliable tool for permanent beam diagnostics the RF synchronization of the laser must be kept up by the regulation automatically for days and weeks. High frequency disturbance sources like electro-magnetic fields and acoustic noise that occur in the accelerator tunnel must be compensated by the regulation driving the piezo fiber stretcher. Long time drifts of air temperature and air humidity that influence primarily the oscillator's fiber length must be compensated by the delay stage.

Figure 6 shows a long-time measurement of the RF synchronized laser for a period of 62 hours. The diagram on top shows the in-loop timing jitter in fs, calculated from the error signal fed into the regulation. The piezo voltage in volts is plotted below. It relates to the deviation per voltage caused by the piezo stretcher with $0.6 \mu\text{m}$ per 10 V. The plot below shows the position of the motor driving the delay stage.

In Figure 6 the compensation of slow drifts can be found in the slow evolution of the piezo voltage. Reaching an upper or lower threshold (30 V, 80 V, respectively) the motorized delay stage is moved automatically. The regulation counteracts the delay stage's change of length by adjusting the piezo voltage. The RF synchronization is kept up all the time during this procedure.

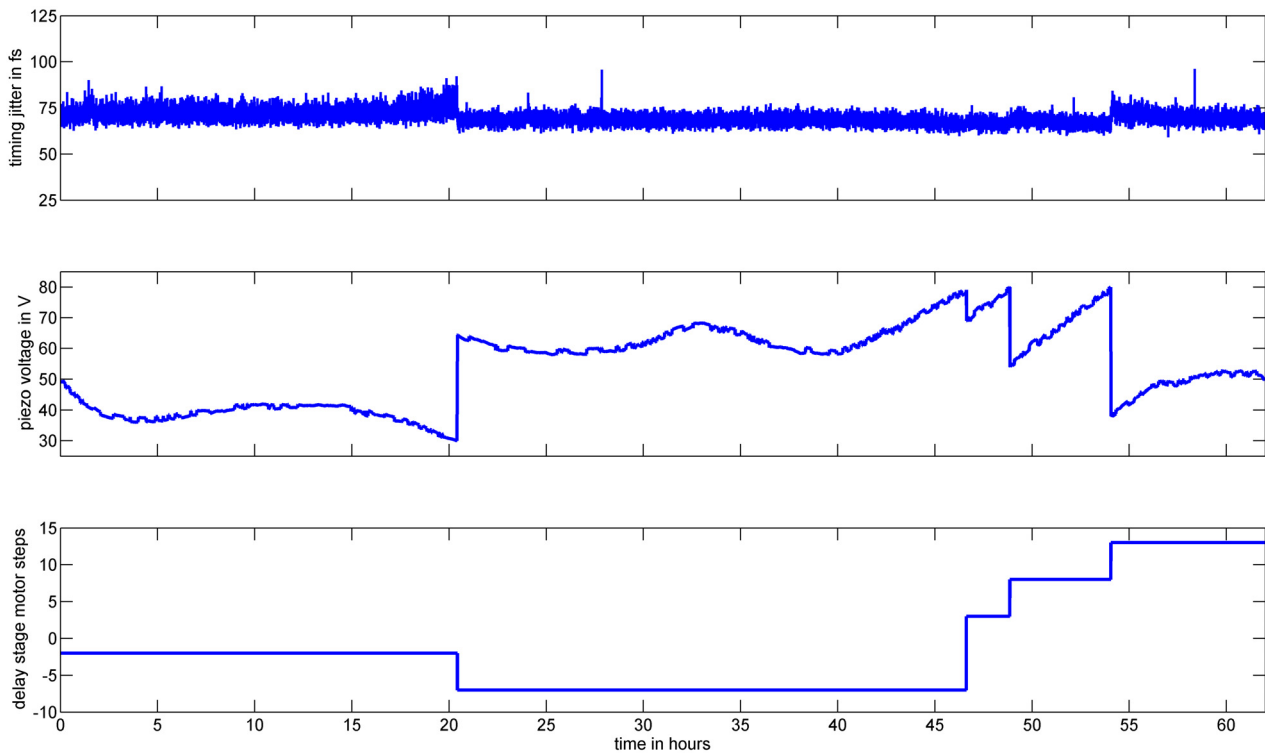

Figure 6: RF synchronization measurement of in-loop timing jitter, piezo voltage and motor position of delay stage for a period of 62 hours.

OUTLOOK

Next steps of commissioning the new EO setup at BC2 are the installation of all components in the accelerator tunnel and the final alignment of the EO monitor.

Besides longitudinal bunch shape measurements behind the first bunch compressor and comparison studies with other EO setups and a TDS at FLASH, bunch arrival time measurements with EO at BC2 and comparison studies with bunch arrival time monitors (BAM) will be conducted.

REFERENCES

- [1] L.-G. Wissmann et al., "Ytterbium fibre laser based electro-optic measurements of the longitudinal charge distribution of electron bunches at FLASH", FEL 2010, Malmoe, Sweden, MOPC10, this conference.
- [2] Felix Lukas Mueller et al., "A Compact Electro Optical Bunch Length Monitoring System - First Results at PSI", FEL 2010, Malmoe, Sweden, WEPA09, this conference.