

RF-BASED SYNCHRONIZATION OF THE SEED AND PUMP-PROBE LASERS TO THE OPTICAL SYNCHRONIZATION SYSTEM AT FLASH

M. Felber[#], M. K. Bock, P. Gessler, K. E. Hacker, T. Lamb, F. Ludwig, H. Schlarb, B. Schmidt,
Deutsches Elektronen Synchrotron - DESY, Hamburg, Germany

J. Breunlin, S. Schulz, L. Wissmann, Hamburg University, Hamburg, Germany

Abstract

At FLASH, UV and soft X-ray pulses with durations in the order of 10 fs are generated. To fully exploit the opportunities provided by these short laser pulses, an optical synchronization system to synchronize external lasers and stabilize the electron bunch arrival time is being constructed. A seeded free-electron laser (FEL) section, called sFLASH, is installed upstream of the existing SASE undulators. After higher-harmonic generation, the femtosecond seed laser pulse needs to be temporally and spatially overlapped with the electron bunch. Furthermore, for time-resolved pump-probe experiments, using an experimental laser and the FEL pulse, the synchronization between pump and probe laser pulses is crucial. While the best performance for synchronizing these lasers within 10 fs will be achieved by using an optical cross-correlator, in this paper we present a precursor that relies on an RF-based locking mechanism. The setup includes a coarse and a fine phase measurement between the laser pulses of the reference and the synchronized system after their conversion to an RF signal.

THE OPTICAL SYNCHRONIZATION SYSTEM OF FLASH

Introduction

In most modern FEL facilities, optical synchronization systems are becoming an important extension of the coaxial cable based radio frequency (RF) timing distribution because they have shown to be capable of providing a point-to-point stability in the order of 10 fs over long distances [1]. Consequently, such a system was developed and installed at DESY for the Free Electron Laser in Hamburg (FLASH) [2] and it is planned for the European XFEL.

In this scheme, laser pulses with durations in the order of 100-200 fs are distributed in phase-stabilized optical fibers along the facility. Their precise 216.667 MHz repetition rate containing very low phase noise serves as timing reference for the most demanding applications. Since not all critical aspects of this complex system have yet been investigated, the system is under constant examination and improvement. Further developments

mainly aim at automation and higher robustness to keep the maintenance at a reasonable level.

One recent upgrade to the system is the installation of a commercial laser from the company OneFive as Master Laser Oscillator (MLO) [3]. This maintenance-free semiconductor saturable absorber-based laser replaces the formerly used self-built fiber laser, which showed disadvantages in terms of reliability in the past.

The MLO pulses are distributed and amplified via self-built erbium-doped fiber amplifiers to several link stabilization units. The mechanical design of these units was recently revised and additionally a major improvement of the incorporated translation stage was achieved. The new link unit design is being manufactured right now and first tests are foreseen for September 2010.

Applications

One of the many advantages of the optical pulses compared to ordinary cw RF distribution is their direct use for beam diagnostics like the bunch arrival time monitor with sub-10 fs resolution [4] and a high resolution beam energy measurement called chicane beam position monitor [5]. These provide the possibility for beam measurement based stabilization and regulation of the accelerating RF (beam-based feedback) [6, 7] allowing for unprecedented arrival time and energy stability of the electron bunches and therefore of the FEL pulses for user experiments.

Another key advantage of a pulsed optical reference is the possibility to lock other lasers, e.g. Ti:Sapphire oscillators, in the facility to fs precision via two color balanced optical cross-correlation [8]. This concerns mainly the injector laser, seeding laser and pump-probe laser. The precise synchronization is based on locking both, the electron beam and the lasers to the same optical reference hence avoiding additional jitter contributions by intermediate systems.

Furthermore, a valuable application of the optical pulse train is the direct or indirect generation of RF signals [9]. When the pulse train is put to a photo detector, the resulting electrical pulse train contains all harmonics of the fundamental optical repetition rate up to the bandwidth of the detector. A single frequency line (e.g. 1.3 GHz for FLASH, 6th harmonic of 216 MHz) can be extracted by simply band-pass filtering the electrical pulse train – this scheme is called direct conversion. The signal-to-noise ratio and therefore the phase noise performance of the extracted RF is limited by shot-noise in the detector. Drifts of the conversion setup remain

[#]Matthias.Felber@desy.de

uncompensated. There are approaches to circumvent these limitations by building a balanced optical-microwave phase detector, enabling for a low noise phase locked loop, but this is not matured and will need more research in the future. Despite the disadvantages, very good results have already been demonstrated with the direct conversion setup [9, 10].

THE SEEDING EXPERIMENT SFLASH

During the 2009-10 winter shut down of FLASH the machine was upgraded in many aspects [11]. After the first accelerating module a third harmonic module was installed which can be used to linearize the longitudinal phase space leading to longer electron bunches (~250 fs) with high peak currents after the bunch compressors.

This enables the possibility for a seeding experiment which was installed between the collimator and the SASE undulators. The seeding pulse is obtained from a Ti:Sapphire laser system after high-harmonic generation (HHG) at wavelengths of 38 nm down to 13 nm [12]. The repetition rate is 10 Hz. These seed pulses of about 20 fs duration have to be spatially and temporally overlapped with the electron bunches in the 10 m long sFLASH undulator. The required synchronization is in the order of 50 fs to avoid FEL radiation fluctuations. A dedicated setup using a streak camera for measuring the initial timing between the electron bunch and the seed laser is installed. The resolution of the camera is about 1 ps [13] and therefore insufficient for precise timing measurements in the fs range. The sFLASH FEL pulses will have a smaller spectral bandwidth as the normal SASE pulses and they are inherently synchronized to the HHG oscillator for pump-probe experiments.

TIME-RESOLVED PUMP-PROBE EXPERIMENT

Since 2005 FLASH offers the possibility to users to perform pump-probe experiments where the pump laser pulse triggers a physical process or reaction and the probe is used to sample the changes of the target. One of them is an amplified Ti:Sapphire pulse with 120 fs FWHM. The FEL pulse duration is in the order of 10 fs if the third harmonic module is inactive and up to 250 fs with the module switched on. The timing jitter between FEL and IR laser pulse can be measured shot by shot using electro-optic sampling diagnostic [14]. This provides the possibility to sort the data after the experiment and the limitation of the timing information is given by the accuracy of the measurement, not by the jitter between the pulses. For future experiments, the resolution obtained by this method is not sufficient. Additionally, synchronization on a fs level opens up the possibility to set the time delay between individual pump-probe pulses. This way, an entire film of a process can be recorded within one burst by imprinting an arrival time slope on the pulse train.

Another advantage is that multiphoton (not pump-probe) experiments, which require two dissimilar photons to overlap in time on the target, can be carried out much more quickly if the timing can be better controlled.

RF-BASED LASER SYNCHRONIZATION

Current Design and Limitations

Right now both, the seed and the pump-probe lasers, are synchronized via a relatively simple RF setup. Coaxially distributed RF frequencies of the accelerator's master oscillator serve as reference signals. The residual timing jitter between lasers and electron beam, or FEL pulse respectively, results from various sources.

Any distortions induced by the locking setup directly degrade the synchronization of the laser. Additionally the beam jitters with respect to the master oscillator reference. The coaxial distribution of reference signals has performance limitations in terms of drifts, microphonic phase distortions, and electro-magnetic interference. Therefore the RF reference at a remote location is not perfectly synchronized to the machine reference, see Fig. 1. This affects the laser locking as well as the LLRF performance which controls the accelerating field. There are schemes under development to improve this limitation [15], additionally these methods are capable of reducing drifts in the field detector. In terms of jitter the LLRF is limited by certain components, especially the ADC that samples the probed fields after down conversion. After the bunch compressors, gradient and phase jitter of the accelerating RF converts to arrival time jitter of the electron beam.

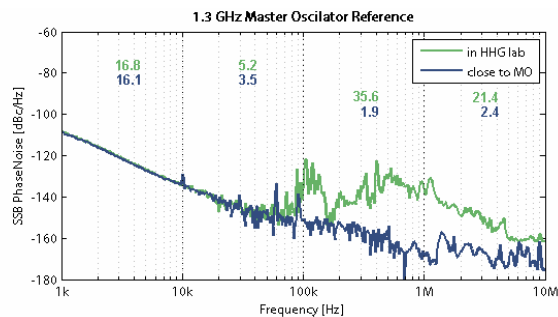

Figure 1: Phase noise of RF reference. The integrated jitter is 16 fs in vicinity of the MO but 45 fs in the HHG laboratory in the interval [1 kHz – 10 MHz]. The numbers show the timing jitter in the corresponding interval in fs.

Concept for Use of Optical Reference

In the new scheme, the reference is extracted from the optical synchronization system. The fiber links distributing the pulses are actively phase-stabilized up to a few kilohertz. While the injector laser is already equipped with an optical cross-correlator, the seed and pump-probe lasers will be locked with conventional RF components in a first step. The pump-probe laser has a repetition rate of 108.33 MHz, the HHG laser of 81.25 MHz but an upgrade of the latter to 108.33 MHz is likely in the future. Therefore we concentrate on that repetition

rate. A simplified block diagram of the setup is shown in Fig. 2. The upper part of the picture shows the reference link end. The optical pulses are amplified before and after a fraction of 10% is reflected back to the link stabilization unit by a Faraday rotating mirror (FRM). All drifts of fiber, cables and components after the FRM remain uncompensated; therefore the distances must be kept as short as possible and the environment must be temperature and humidity stabilized. The optical power monitor can be used for calibration of the amplifier and for diagnostic purposes. For the conversion to electrical signals an InGaAs photo diode with a bandwidth of > 10 GHz is used. The RF components are placed in a temperature stabilized 19°C-crate close to the diode to avoid drifts and signal attenuation. Three different harmonics are filtered out of the pulse train: the fundamental 216 MHz (then divided down to 108 MHz), 1.3 GHz and 9.1 GHz. The same frequencies are generated from the Ti:Sapphire pulse train. All six signals are equipped with directional couplers for diagnostics. After phase detection in low-noise double balanced mixers, the outputs are low-pass filtered and amplified. The 108 MHz phase serves as a coarse monitor to find the

correct bucket of the two higher frequencies. Due to the ambiguity of the frequency division process, the divider has to be reset each machine trigger to avoid the wrong 216 MHz bucket. The 1.3 GHz signals provide finer phase detection. Finally the 9.1 GHz mixer output provides the most sensitive phase comparison.

For setting up the phases, in the first step a 1.3 GHz vector modulator is used to shift the phase of the locked laser to the desired position with respect to the electron beam. Afterwards, the manual phase shifters of the 108 MHz and 9.1 GHz references are used to adjust their mixer outputs to zero (90° condition). Thereby all three reference phases are set and since all frequencies line up in their zero crossing each 108 MHz period, if necessary, it will be relatively easy to re-establish the RF lock in automated steps from coarse to fine synchronization.

The mixer output is sampled at 125 kHz followed by a DSP-based digital PID controller which provides the feedback signal. The amplified DAC output drives a piezo which changes the Ti:Sapphire laser cavity length and therefore the output frequency and phase.

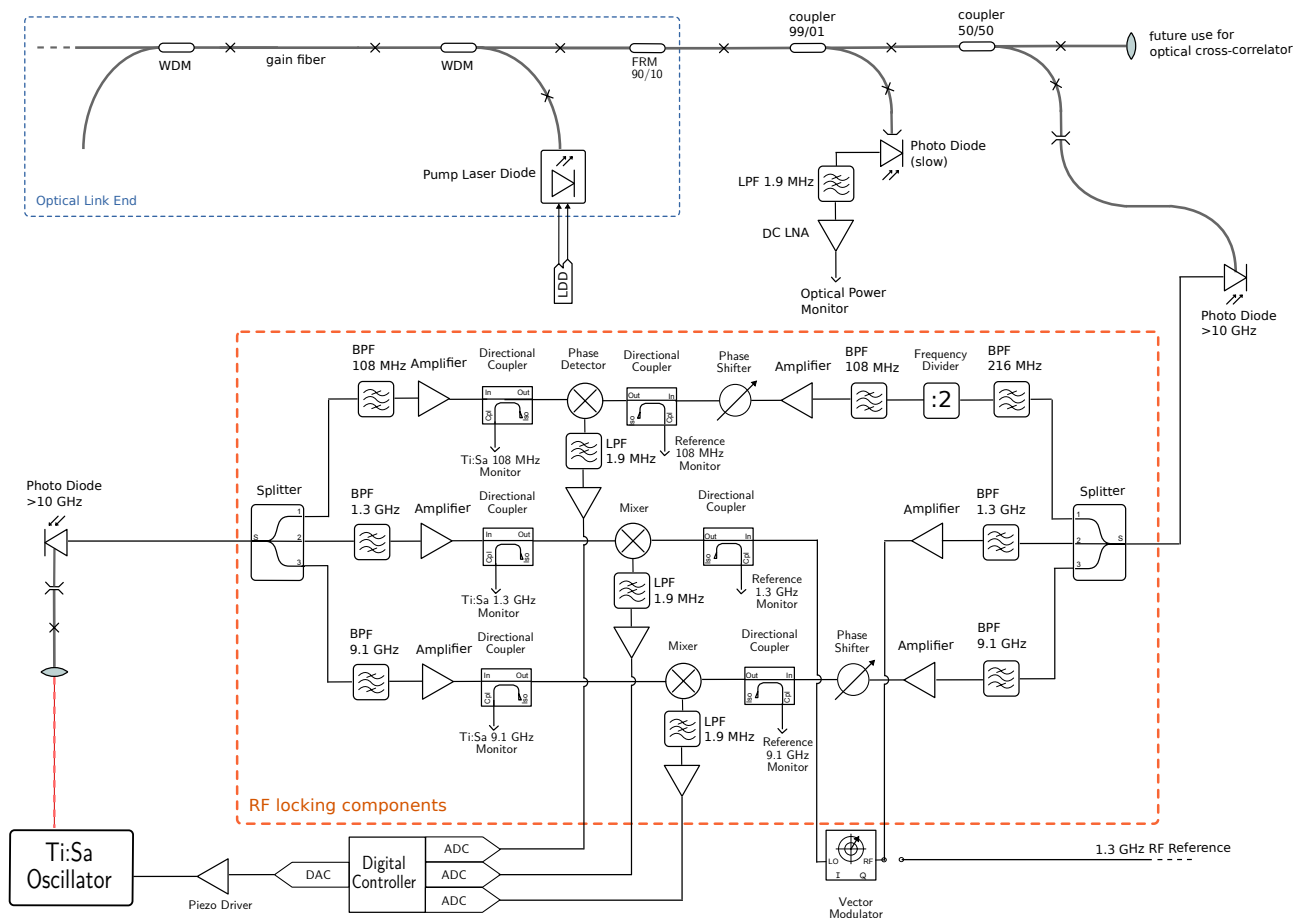

Figure 2: Block diagram of the main components for an RF-based lock of a 108 MHz Ti:Sapphire laser oscillator to the optical synchronization system of FLASH.

STATUS OF THE PROJECT

All components of the setup are ready for assembly which will be done during Sept/Oct 2010.

A stabilized fiber link which end in the laser building was already constructed earlier. A second stabilization unit dedicated specially for the HHG laser link is almost completed. The link unit uses a balanced optical-cross correlator [16] to measure the relative timing between the reference pulses directly emitted from the MLO and the pulses that travelled to the link end and back. The two pulse trains are overlapped in a type-II PPKTP crystal for sum frequency generation. To generate a balanced signal, the laser pulses traverse in forward and backward direction through the crystal. Using the difference of the second harmonic signal generated at each passage, the effects of amplitude fluctuations of the laser are strongly suppressed.

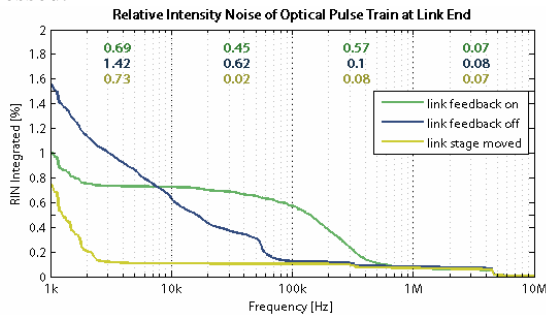

Figure 3: Integrated amplitude noise of the optical reference signal when pulses overlap in link unit with length stabilization feedback on (green), feedback off (blue), and when they do not overlap (yellow). Numbers display contribution of corresponding interval.

Measuring the amplitude of the optical pulses at the end of the >200 m long fiber link when it is actively length stabilized (Fig. 3, green line), unexpected high intensity noise was observed. This degrades the phase noise of the electrical signal after photo detection due to the amplitude to phase conversion effect [17] in the diode (Fig. 4, green line). The source of the amplitude noise is an interaction of the two pulses in the link setup; it vanishes if the pulses are separated by moving a motorized delay stage (Fig. 3, yellow line).

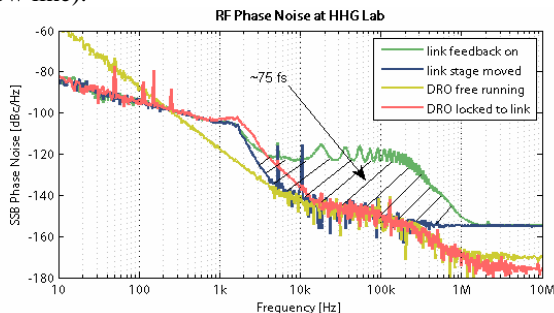

Figure 4: Phase noise of RF signals at the link end when pulses overlap in link unit with length stabilization feedback on (green) and when they do not overlap (blue). Phase noise of DRO free running (yellow) and locked to the stabilized link pulses (red).

Comparing the integrated phase noise of an RF signal obtained from the stabilized link (Fig. 4, green line) with the signal when the delay stage is separating the pulses (Fig. 4, blue line), additional timing jitter in the order of 75 fs is observed in the frequency interval between 1 kHz and 1 MHz.

In tests, we were already successful in suppressing the amplitude noise degradation effect of the optical pulse train. However, it was incompletely eliminated in the used link unit. As a first workaround a dielectric resonator oscillator (DRO) was locked to the optical reference. It provides a low phase noise signal at offset frequencies above the locking bandwidth and follows the optical reference below the locking bandwidth (Fig4, red line), providing a suitable RF reference for the synchronization of the Ti:Sa laser.

CONCLUSION AND OUTLOOK

The FLASH optical synchronization system undergoes steady investigations and improvements. Promising results have been demonstrated for the beam-based feedback stabilization of the electron bunch energy and timing jitter and for the stabilization of the injector laser. In this paper, we presented the concept for an RF-based synchronization of the seed and pump-probe lasers which will be implemented in the near future. Later, the performance will be further improved by the use of an optical cross-correlator. Once these methods are established for permanent operation, they will provide unprecedented stability and new possibilities for the users at FLASH.

ACKNOWLEDGEMENTS

This work is partly supported by "IRUVX-PP" an EU co-funded project under FP7 (Grant Agreement 211285)

REFERENCES

- [1] F. Loehl et al, proceedings EPAC 2008, TUPC135
- [2] S. Schulz et al, proceedings FEL 2009, WEPC72
- [3] S. Schulz et al, these proceedings, THPA05
- [4] M. K. Bock et al, proceedings IPAC 2010, WEOCM02
- [5] K. Hacker et al, proceedings FEL 2009, WEPC70
- [6] W. Koprek et al, these proceedings, THOAI2
- [7] F. Loehl et al, Phys. Rev. Letters 2010, 104, 144801
- [8] S. Schulz et al, proceedings PAC 2009, TH6REP091
- [9] M. Felber et al, proceedings PAC 2009, TH6REP088
- [10] S. Hunziker, proceedings DIPAC 2009, TUPB43
- [11] K. Honkavaara et al, proceedings IPAC 2010, TUOARA01
- [12] H. Delsim-Hashemi, proceedings IPAC 2010, TUPE009
- [13] R. Tarkeshian, proceedings IPAC 2010, MOPD091
- [14] A. Azima et al, proceedings DIPAC 2007, WEPC13
- [15] F. Ludwig et al, proceedings IPAC 2010, TUPEA041
- [16] F. Loehl et al, proceedings PAC 2007, FROAC04
- [17] B. Lorbeer et al, proceedings DIPAC 2007, WEPB08