

RECENT DEVELOPMENTS OF THE BUNCH ARRIVAL TIME MONITOR WITH FEMTOSECOND RESOLUTION AT FLASH

M. K. Bock*, M. Felber, P. Gessler, K. E. Hacker, F. Loehl,
F. Ludwig, H. Schlarb, B. Schmidt, J. Zemella, DESY, Hamburg, Germany
S. Schulz, L.-G. Wissmann, University of Hamburg, Germany

Abstract

The electron Bunch Arrival time Monitors (BAM), based on electro-optical modulation, present an integral part of the optical synchronisation system, which is now being installed and commissioned at the Free-electron LASer in Hamburg (FLASH). Built on the experiences with first prototypes, the most recent version of the BAM, installed prior to the first bunch compressor, includes essential changes affecting the optical layout, the mechanical and thermal stability as well as the electronics for read-out and controls. The experiences with installation as well as the scope of improvements as to simplification and long-term stability will be presented.

INTRODUCTION

Free-electron lasers like FLASH and the planned European XFEL generate x-ray light pulses with durations in the order of a few 10 fs. In order to enhance the resolution of pump-probe experiments, precise information on the timing of both the FEL light pulses and pulses from external lasers is required. Especially for the seeded FEL operation at FLASH (sFLASH experiment), it is crucial to stabilise the bunch arrival time to values of 20 to 30 fs. The information on the bunch arrival times at various locations of the FEL facility is projected to be used in realtime feedback loops on accelerator subcomponents which predominantly contribute to the timing jitter of the electron bunches.

BUNCH ARRIVAL TIME MONITORS AT FLASH

The electro-optical BAM measures the electron bunch arrival time relative to an optical timing reference. Therefore this monitor is integrated into the laser-based synchronisation system, which connects to various end-stations installed at FLASH, see Fig. 1. The components marked in light grey will be installed and commissioned within the upcoming months. The synchronisation hutch contains the main components for generation and distribution of the optical timing reference. The latter is provided by a pulse train of ultra-short soliton laser pulses from the Master Laser Oscillator (MLO) with a repetition rate of 216.67 MHz. For details on the current status and performance of subcomponents of the laser-based synchronisation system, refer to [2].

Up to now, four BAMs are installed and commissioned. The relative simple design of the first two prototypes of the BAM, which are installed downstream of the main linac, already allowed for arrival time measurements with sub-10 fs resolution [1]. The first one of the two revised BAMs had been installed in 2009 directly before the entrance of the first bunch compressing magnetic chicane (BC2), in May 2010 another congenerous BAM was installed behind the exit of BC 2. It is planned to install a fifth BAM, located directly behind the exit of the last seeding undulator, in the beginning of 2011.

Principle of Operation

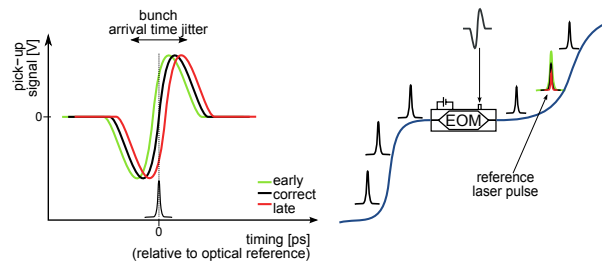

Figure 2: Schematic of the BAM detection scheme utilising electro-optical modulation.

The key component of the BAM detection scheme is a commercial Mach-Zehnder type Electro-Optical Modulator (EOM). This component is used to imprint the information on the arrival time of the electron bunches on the reference laser pulses through modulating their amplitude. For this purpose, a beam pick-up is mounted around the vacuum chamber of the beam pipe with four button type pick-up electrodes (see top of Fig. 3). Through combining the signals of two opposing electrodes of the pick-up the dependence of the arrival time measurement on the position of the electron bunch in the vacuum chamber can nearly be eliminated [4]. A traversing electron bunch induces a bipolar RF voltage signal, which shape is determined by the charge distribution of the electron bunch folded with the beam pick-up response function. The detection principle is sketched in Fig. 2. The timing of the optical reference pulse is adjusted such that the pulses sample the pick-up signal at its zero crossing. At this operation point the inherent dependence of the BAM arrival time measurement on the bunch charge is reduced. All subsequent electron bunches which time of arrival deviates from this reference

* corresponding author, e-mail: marie.kristin.bock@desy.de

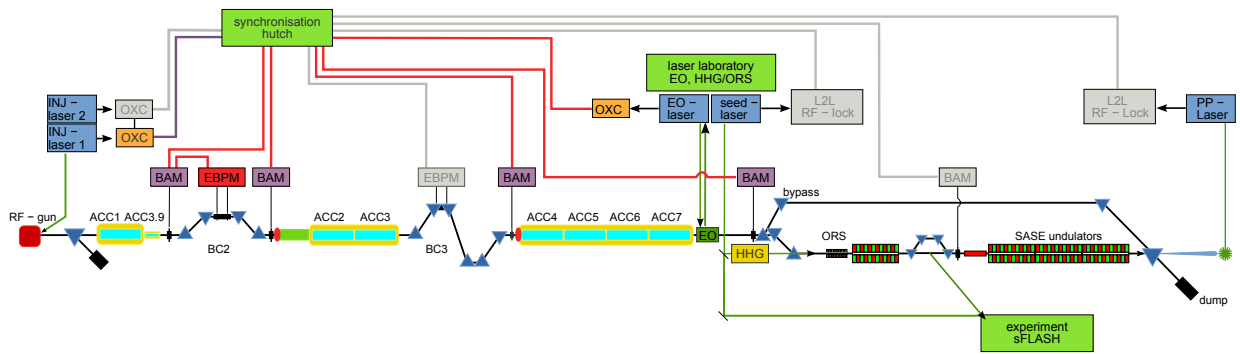

Figure 1: Schematic of the laser-based synchronisation system at the upgraded FLASH accelerator facility.

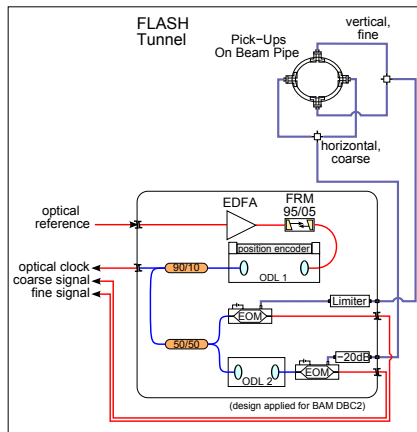

Figure 3: Schematic of the latest optical front-end design of the most recent BAM, installed after the first bunch compressor.

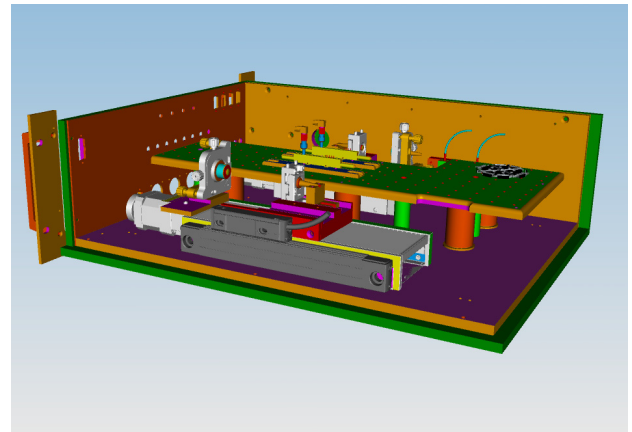

Figure 4: Schematic of the most recent BAM chassis. Visible are the two motorised delay stages and the four posts for the peltier elements underneath the aluminium plate on which both EOMs are installed.

point, cause an amplitude modulation of the sampling laser pulses. The BAM measures the arrival time with two channels of different resolution. A fine channel, where the signal has a steep slope at the zero crossing which translates into a high bandwidth of this fine detection channel, but limitates the measurement range to a few picoseconds (4 - 6 ps). And a coarse channel with a lower bandwidth but with an enlarged measurement range of 40 - 60 ps. For further details refer to [1, 3]

Opto-Mechanical BAM Front-End

Fig. 3 shows the opto-mechanical layout of the BAM front-end. The fibre link ending is designed equally for all remote terminals of the synchronisation system, comprising an Erbium-doped Fibre Amplifier (EDFA) and a Faraday Rotating Mirror (FRM), which reflects 5 % of the signal amplitude backwards through the EDFA in the direction of the fibre link length-stabilisation unit, which is located in the synchronisation hutch (Fig. 1). The remaining 95 % of the laser pulse energy are distributed in the Polarisation Maintaing (PM) fibre section of the BAM, including two Optical Delay Lines (ODL) and two EOMs.

The BAM delivers three output signals, an optical clock for the ADCs and the amplitude modulated pulses from the coarse and fine channel. Fig. 4 shows a design drawing of the BAM chassis with all electric and mechanical components installed.

To summarise, the two recently installed BAMs comprise a revised design. One of the major design changes concerns the usage of two custom motorised linear stages, which are suited for high duty cycles. Furthermore, self-spliced PM optical delay lines and a temperature stabilisation of the complete BAM chassis by the use of four peltier elements has been included. The fibre management was also improved for simplification of the assembly. Further improvements regarding longterm stability and reliability of the optical BAM front-end will be included in an upcoming design review. One important issue concerns the fibre coupled optical delay stages, where mechanical stress is exerted on the fibre collimators with every motor movement. The layout using PM fibre-components has some drawbacks, such as time-consuming assembly, high costs as well as relatively large overall losses in optical power, up to - 15 dB in the worst case. In addition, the fusion

splicing procedure of the PM-components results in a relatively large total fibre length, about 8 m, which is not compensated for length variations induced by changes in air temperature or humidity.

Electronic BAM Front-End

Beside the optical infrastructure, a variety of electronics for control and read-out are required to operate the electro-optical BAMs. Those electronics need the possibility of remote control access via the accelerator's control system, i.e. DOOCS in the case of FLASH. Many of the high demands which are made on the electronics, necessitated the development of custom solutions. Regarding the read-out system for the modulated laser pulses coming from the BAMs, a sophisticated analog and digital hardware is needed to generate high quality signals. To enable real time feedbacks based on the calculated bunch arrival times, several major tasks for digitising and processing of the signals are addressed to the electronic front-end. There has been no off-the-shelf hardware available which could fulfill all of the addressed tasks, therefore a specialised hardware has been developed at DESY in cooperation with Warsaw University. The so called Advanced Carrier Board (ACB), which is a universal digital VME carrier card with a FPGA and four fast ADC channels as well as additional analog opto-electronic front ends. The complete processing chain and the different interconnections to other systems are very complex. Continuous developments are still going on to finally offer an automated and stable operation, with improved signal quality, reduced clock jitter and reliable firmware. With regard to the XFEL, the electronics, such as the ACB, needs to be available on the MircoTCA platform. In this context cooperation with industry and other departments has been established to develop a commercial product. In this case the focus of work at DESY will be on programming of the complex firmware and software.

Commissioning of the BAMs

During the commissioning process, the correct operation point at the zero crossing of the voltage transient from the beam pick-up has to be found. For this purpose, the timing of the reference laser pulses has to be shifted a large amount relative to the timing of the pick-up signal. Because the longest motorised stage, with a travel range of 135 mm, covers only 363 ps time delay, the timing of the reference laser pulses is changed by directly shifting the 1.3 GHz phase of MLO, using a vector modulator (VM). In order to place the operation point of both signal channels, i.e. fine and coarse, of all BAMs at the same 1.3 GHz phase, a rough timing matching is done by adjusting the RF cable lengths between the beam pick-up electrodes and the EOMs. For a fine adjustment within a few picoseconds range, corresponding to a few millimeter change of optical path length, the motorised delay stages in the BAM chassis are used. Fig. 5 shows fine and coarse signals of three BAMs, all of

them aligned at the operating point. The coarse signals reveal the shape of the RF voltage transient from the beam pick-up after attenuation. The different heights of the signal result from different attenuators and optical power levels. The oscillatory shape of the fine signals are caused by overrotation, a feature of the EOMs, occurring when the applied voltage exceeds 5 V. During operation the bunch arrival time is measured with the fine channel while the coarse channel is used to apply a motor feedback on the first ODL which is moved each time a bunch arrival time change was detected, in order to permanently keep the laser pulses at the zero crossing of the RF pick-up signal.

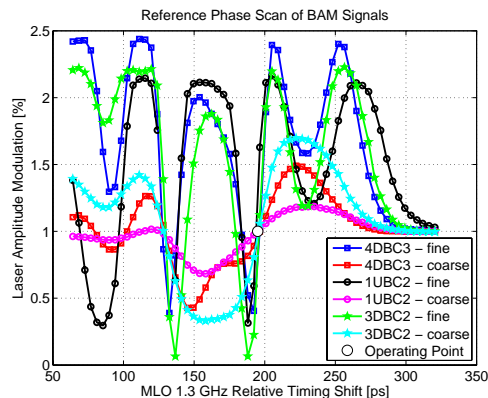

Figure 5: Simultaneous signal scan with three BAMs around the reference 1.3 GHz phase of the MLO at 92 deg or 197 ps.

SUMMARY AND OUTLOOK

Four electro-optical Bunch Arrival Time Monitors of consecutive design generations are currently installed and commissioned at FLASH. The recent BAM front-end already involves several improvements which will be furthered in an upcoming design review. Both the optical and the electric front-end of the BAM proceed towards stable and reliable operation.

REFERENCES

- [1] F. Loehl, et. al., Phys. Rev. Lett., Volume 104, Issue 14, 144801 (2010)
- [2] S. Schulz, et. al., 48th ICFA Advanced Beam Dynamics Workshop on Future Light Sources, FLS 2010, Stanford, USA, 1-5 March
- [3] M.K. Bock, et. al., FEL 2009, Liverpool, England, 23-28 August
- [4] K.E. Hacker, et al., DIPAC 2007, Venice, Italy 23-25 May
- [5] S. Schulz, et al., 'Precision Synchronization of the FLASH Photoinjector Laser', IPAC 2010, Kyoto, Japan, 23-28 May