

# Laser to RF Conversion

## BOM – Sagnac Loop

Overview

Design Issues

Measurement Highlights

## Direct Conversion

Amplitude / Power

Jitter

Laser Lock

Drift

# L2RF as part of the synchronization system

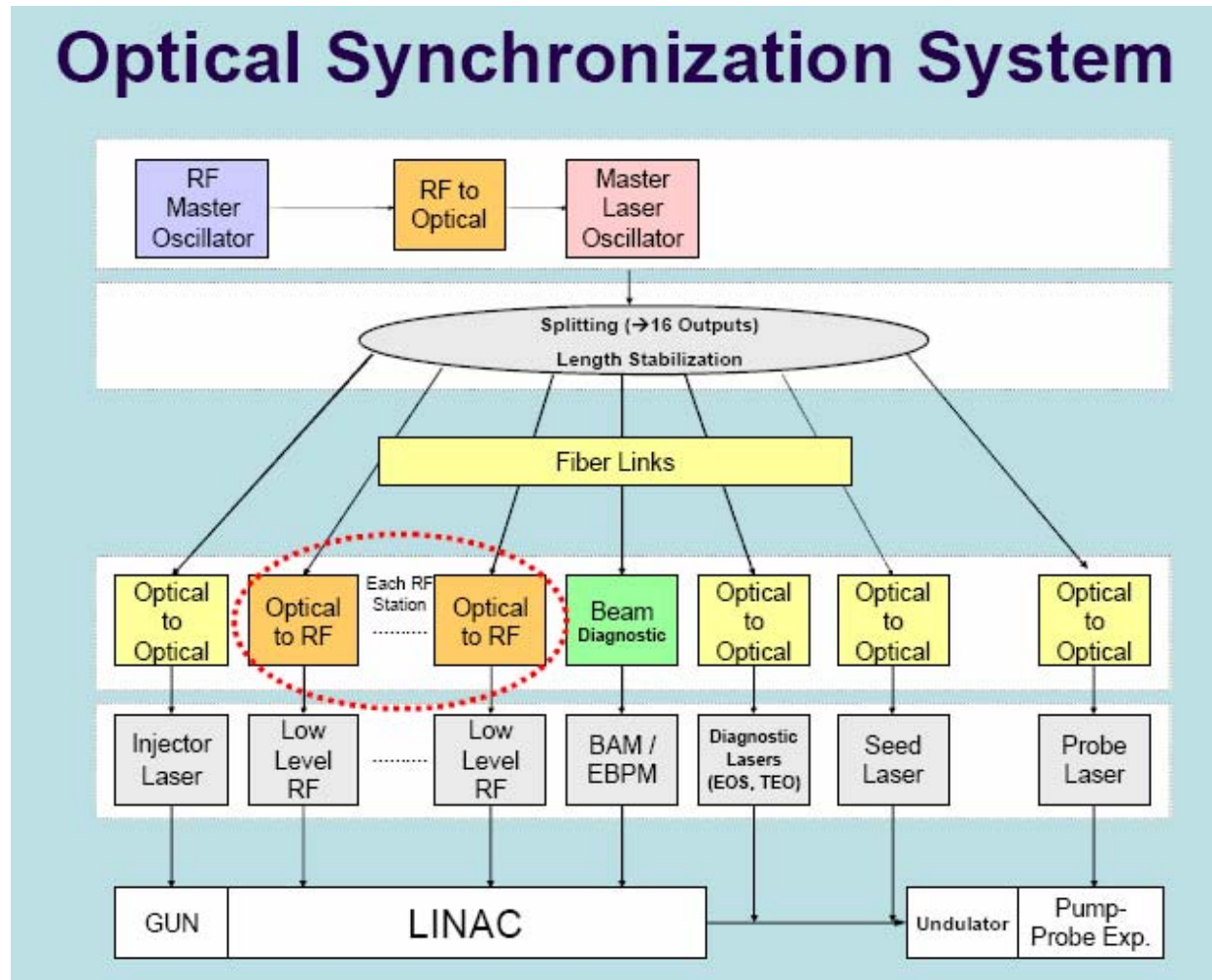

# BOM based on Sagnac Loop

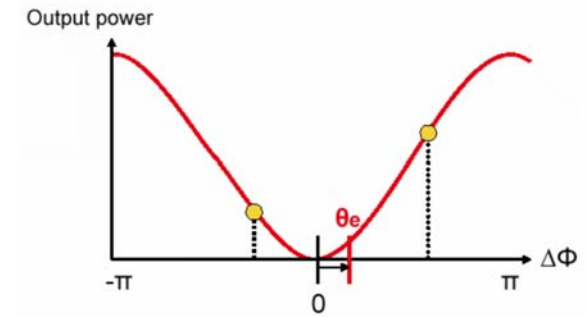
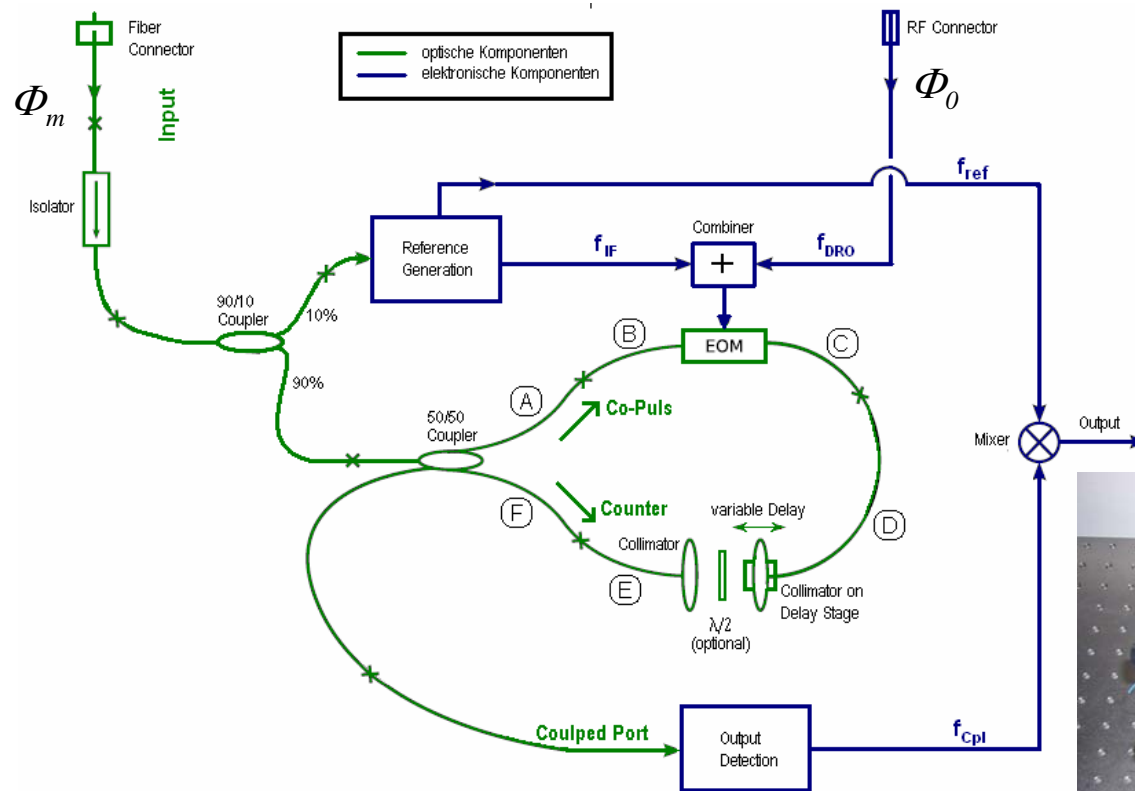

$$K_d = \frac{V_d}{\Theta_e} \propto P_{avg} \Phi_0 \Phi_m$$

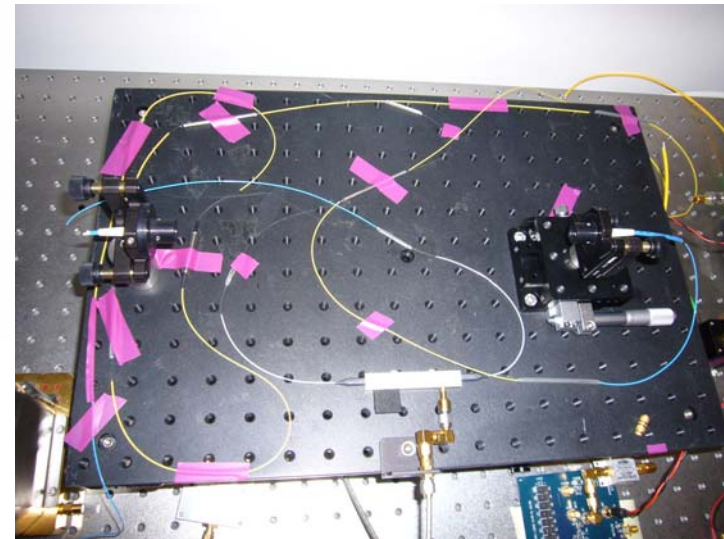

# RF Part – Reference Generation

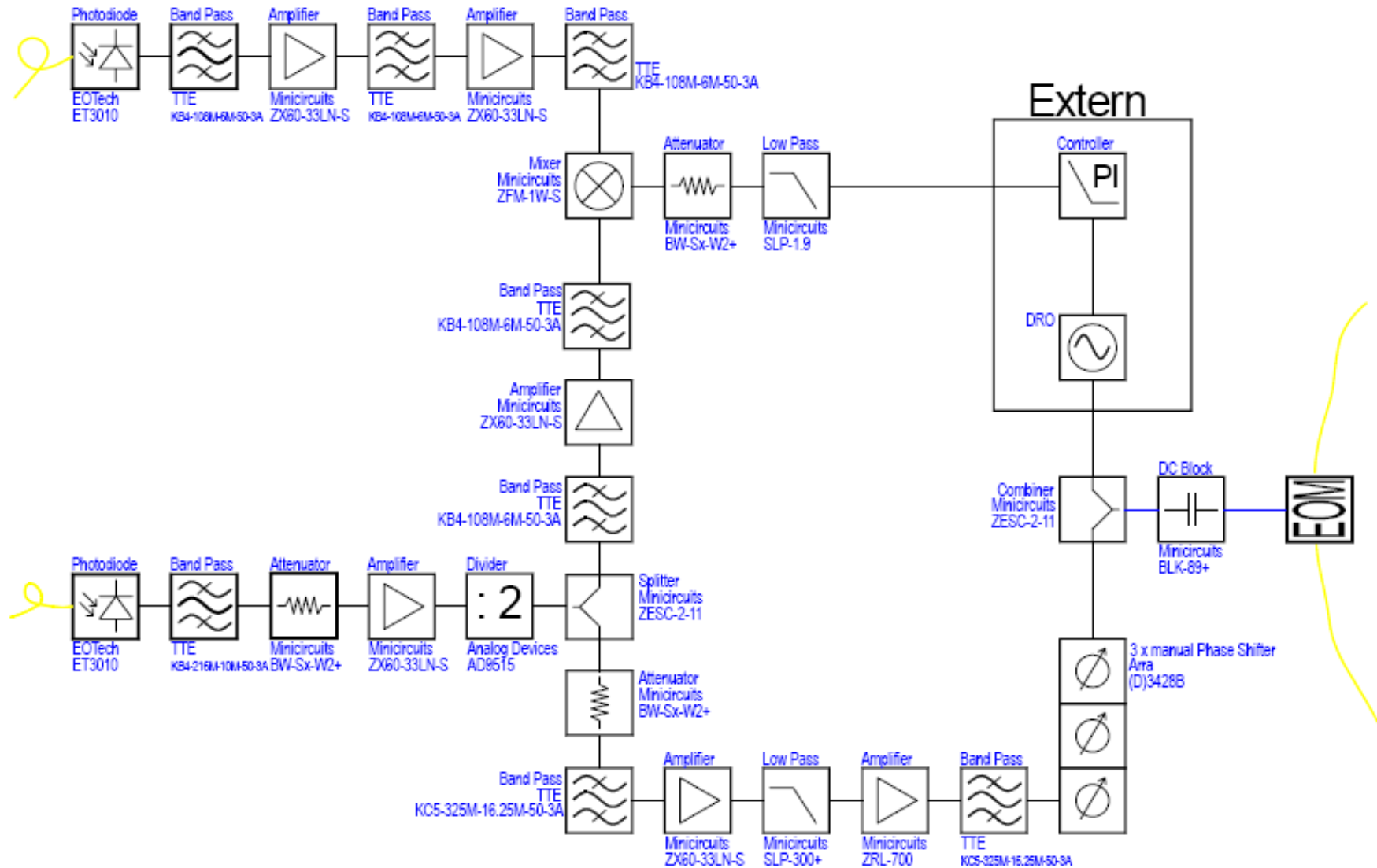

# Drawbacks

- At 1.3 GHz the counter-propagating pulse cannot be neglected:

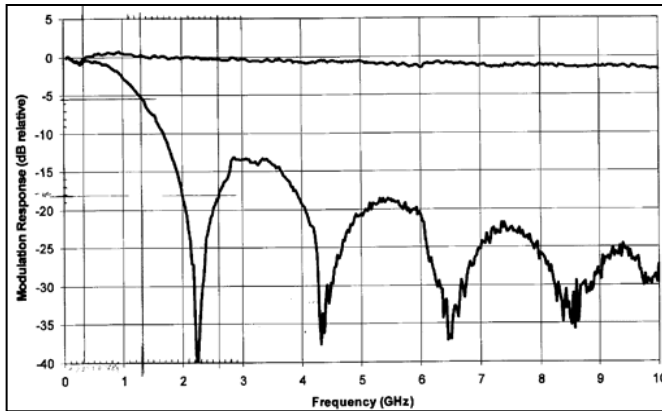

- The counter-propagating pulse cannot be in the max/min  $\rightarrow$  phase noise of reference counts:

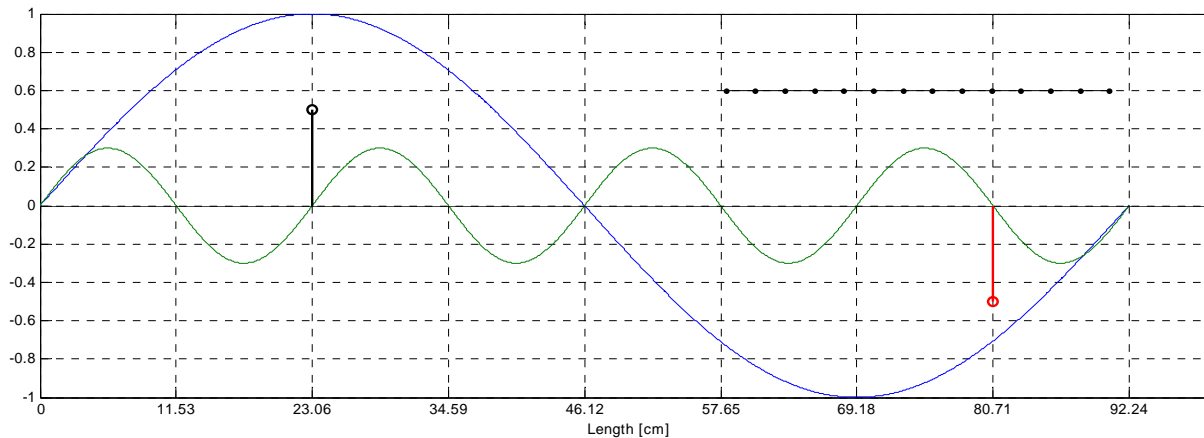

- Slope at 1.3 GHz is  $\sim 8$  times smaller compared o 10.2 GHz



# 'Gating' of Modulation Voltage

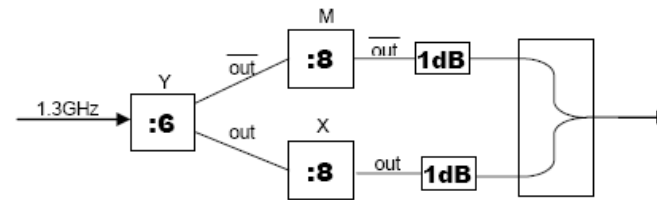

3 x HMC394 Attenuator ZESC-2-11

General Setup Block Diagram

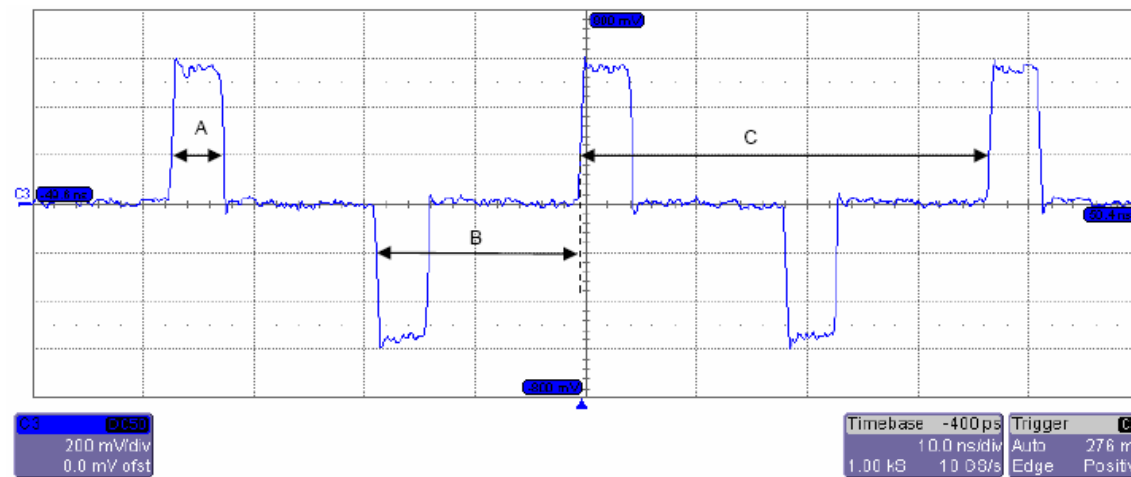

- |   |                       |                                     |
|---|-----------------------|-------------------------------------|
| A | Pulse width           | ca. 5ns (divide by 8)               |
| B | Laser Rep-rate $f_R$  | here 54MHz (general 40MHz...216MHz) |
| C | Divider out frequency | here 27MHz (general $f_R/2$ )       |



# Measurements Highlights – Setup 1

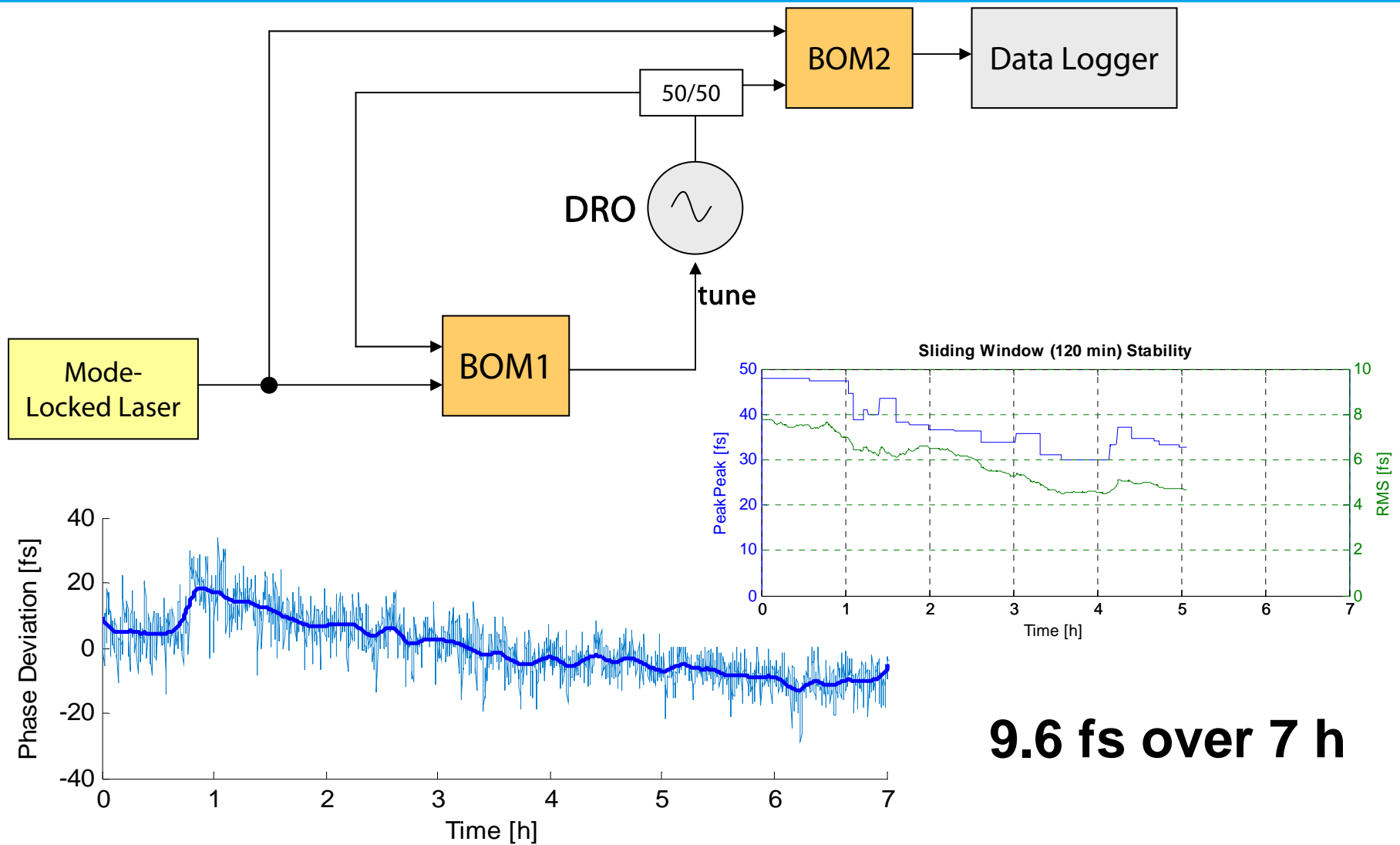

**9.6 fs over 7 h**



# Measurement Highlights – Setup 2

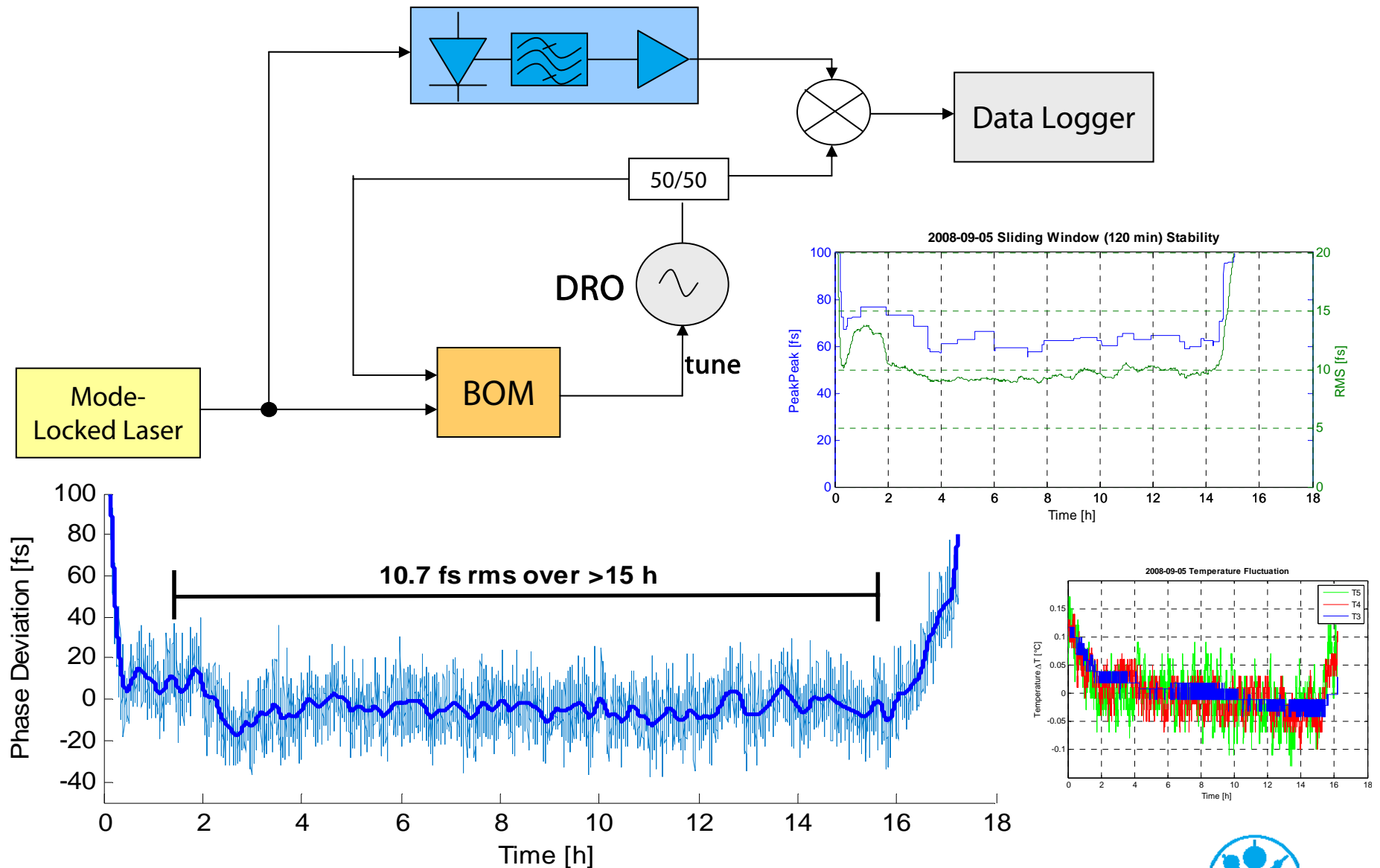

# Direct Conversion

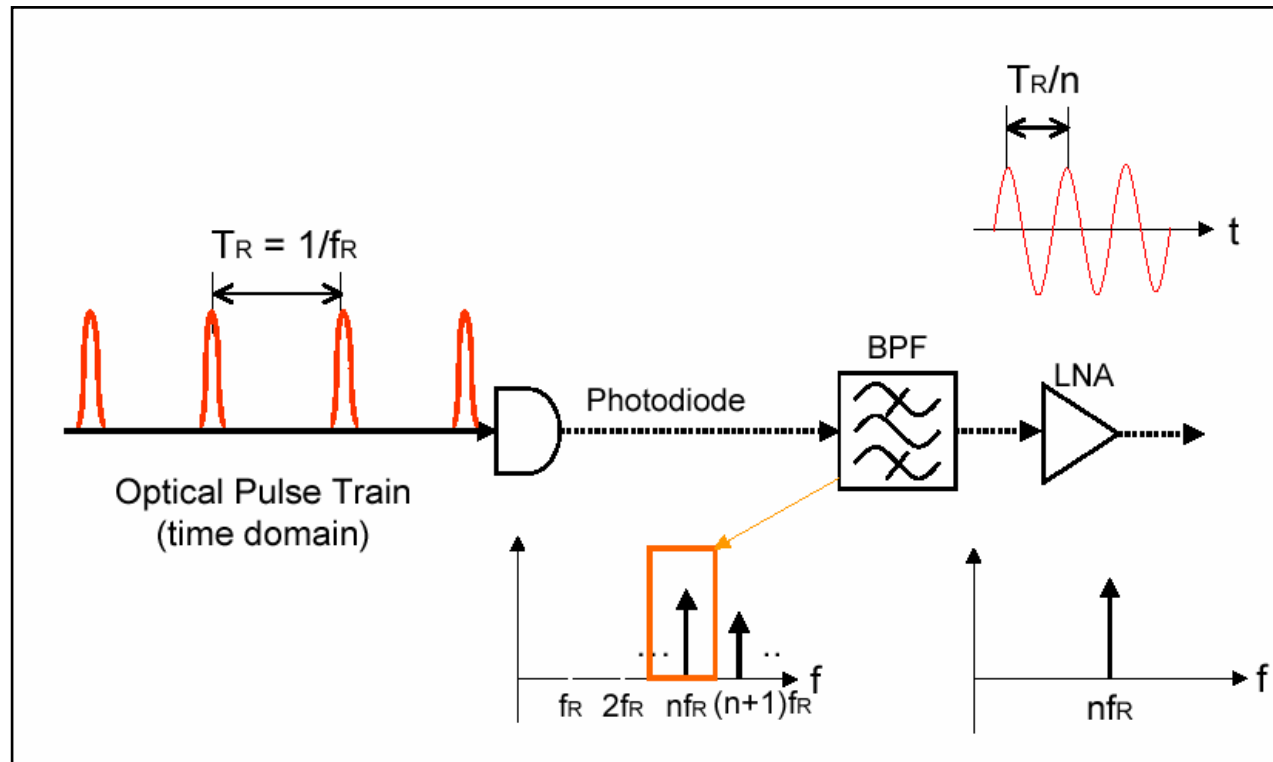

- AM-PM conversion
- Drift of photo detector
- Drift of filter and amplifier ('open loop')

# Amplitude / Power

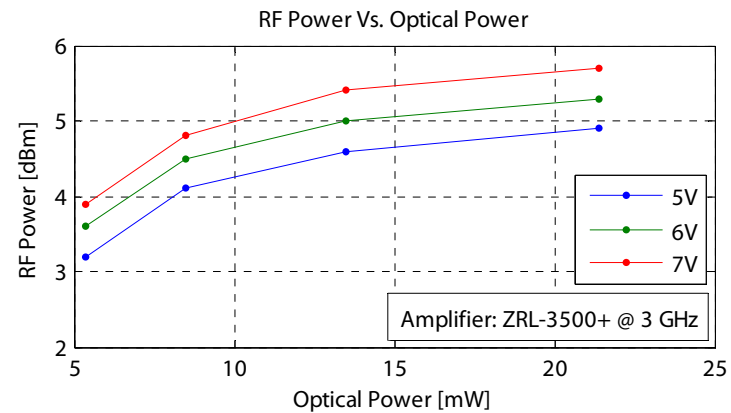
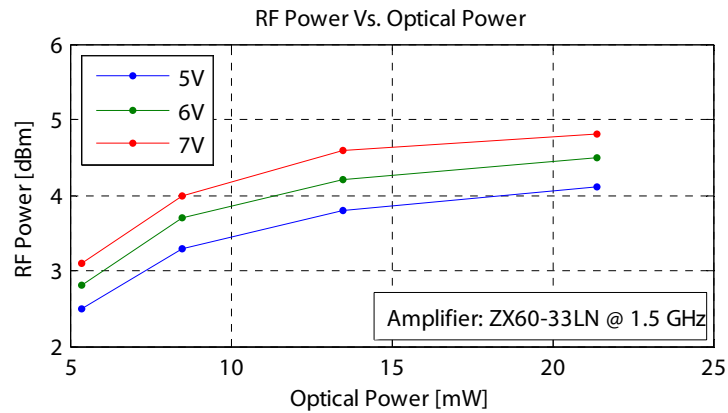

## RF amplitude noise

opt. Pwr	13.4 mW	8.5 mW	0.8 mW	0.4 mW
Setup				
6V, ZRL3500, 3GHz	-	$5.0 \cdot 10^{-5}$ ( $8.7 \cdot 10^{-5}$ )	$1.1 \cdot 10^{-4}$ ( $2.0 \cdot 10^{-4}$ )	$1.7 \cdot 10^{-4}$ ( $3.1 \cdot 10^{-4}$ )
6V, ZX60-33, 3GHz	$4.2 \cdot 10^{-5}$ ( $7.3 \cdot 10^{-5}$ )	-	-	$1.6 \cdot 10^{-4}$ ( $2.9 \cdot 10^{-4}$ )
6V, ZX60-33, 1.5GHz	$5.0 \cdot 10^{-5}$ ( $7.7 \cdot 10^{-5}$ )	-	-	$1.8 \cdot 10^{-4}$ ( $3.0 \cdot 10^{-4}$ )

AM noise on the extracted RF signal for different setups [1 kHz-10 MHz]. (bracketed: [1 kHz- 40 MHz])  
 Almost all is high frequency noise >1 MHz

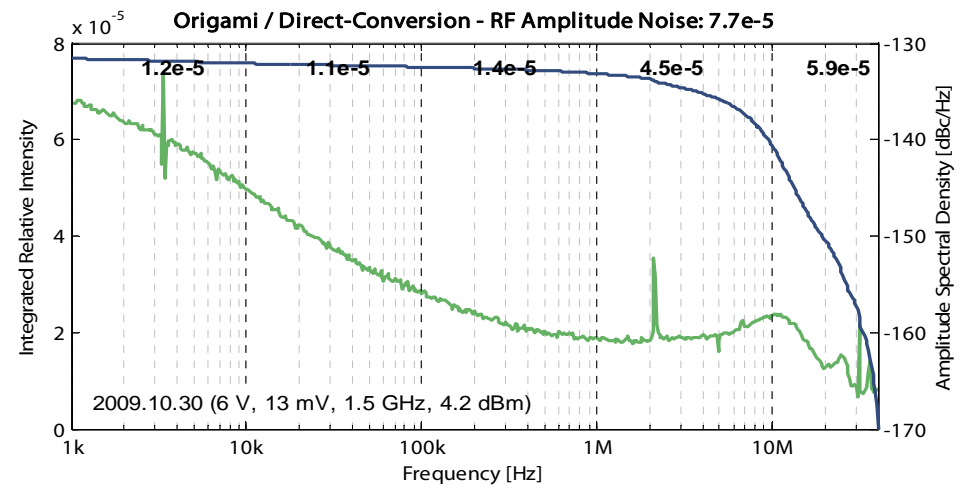

# Jitter

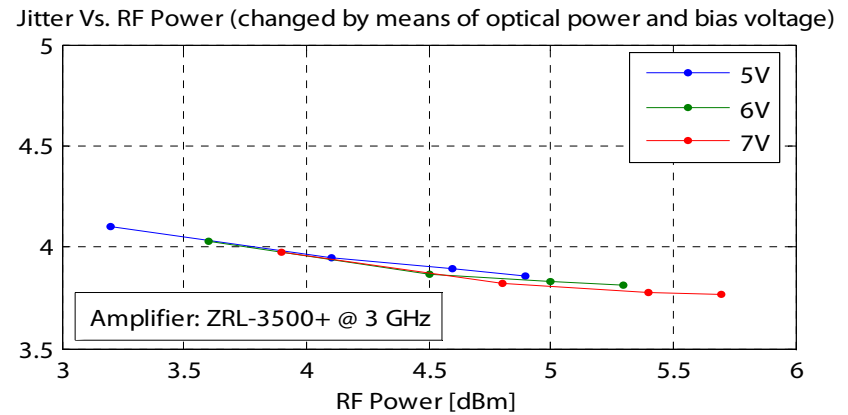
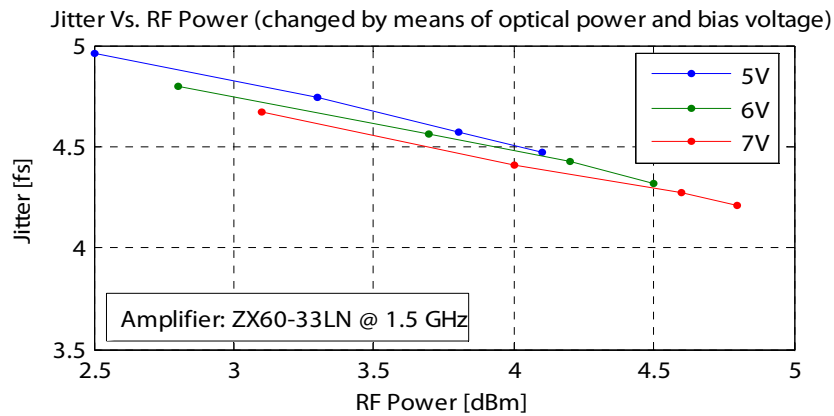
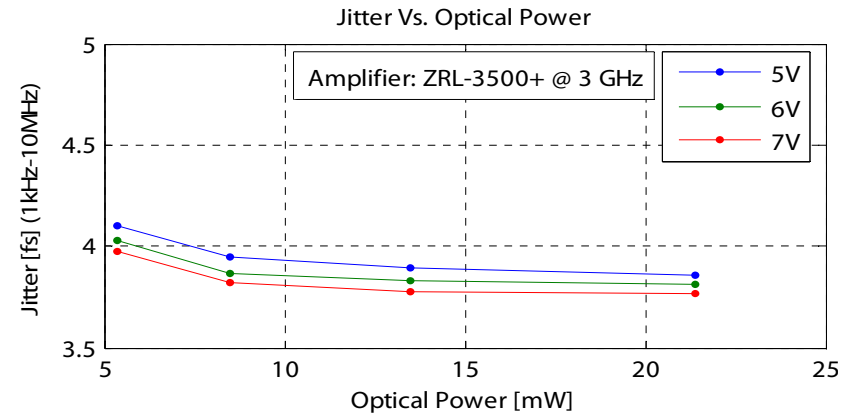
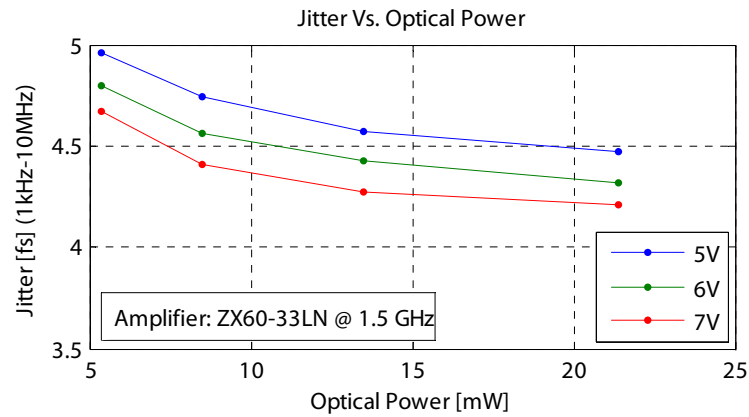

# Phase Noise & Jitter

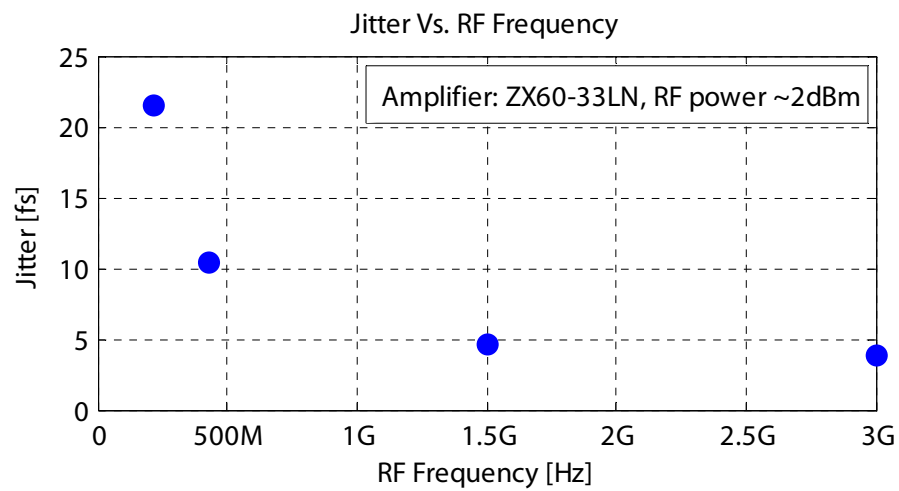
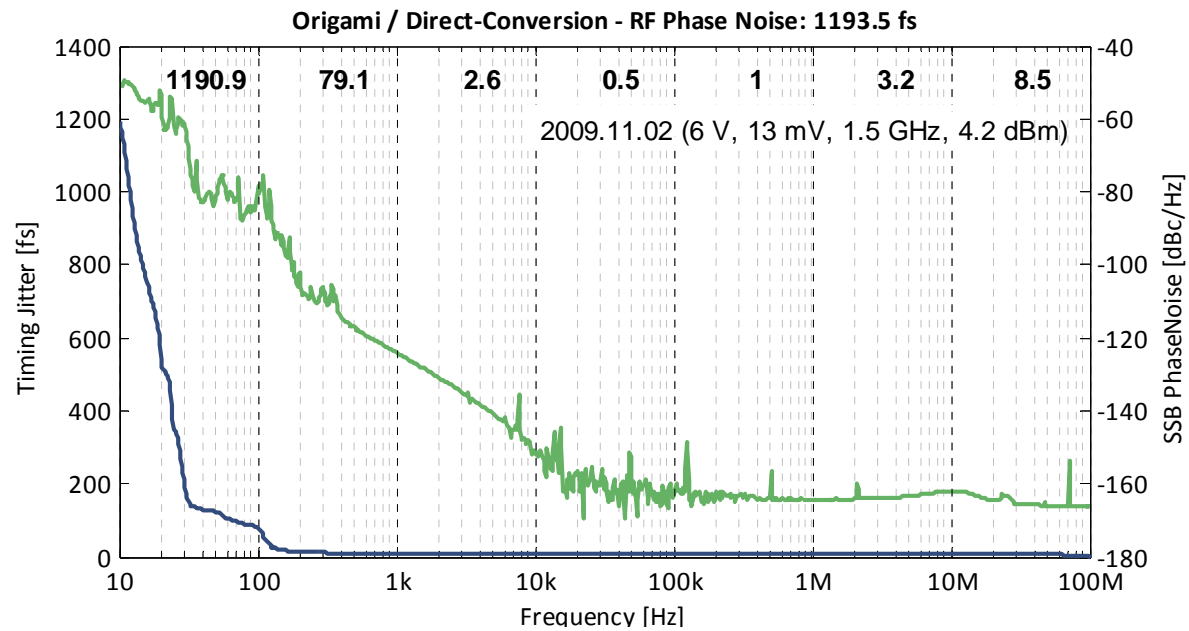

# Laser RF Lock

Origami Locked to MO @ 214 MHz - Out-of-Loop Albis PD

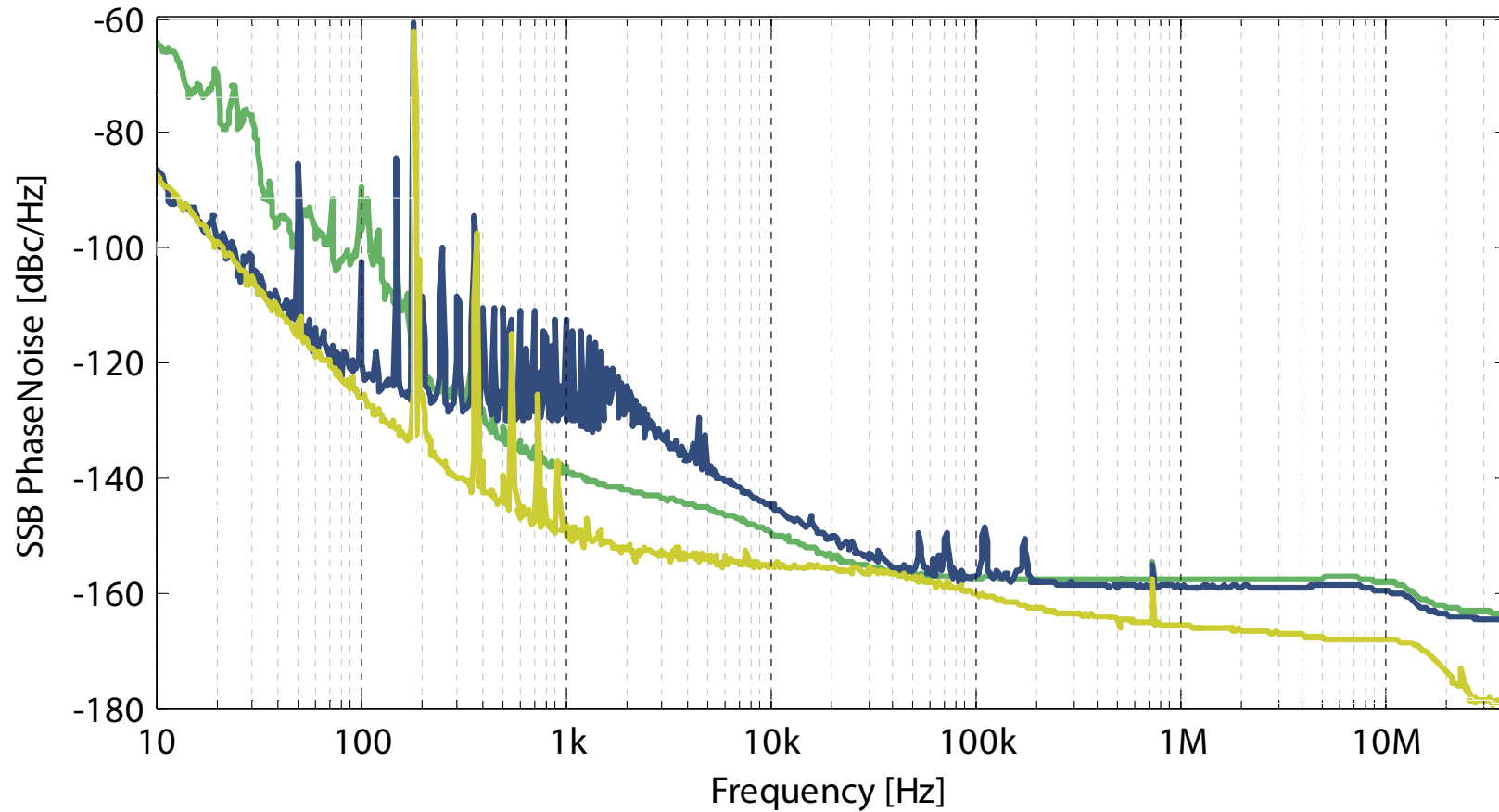

# Long Term Drift

2009-11-09 Drift - Locked to R&S SMR40

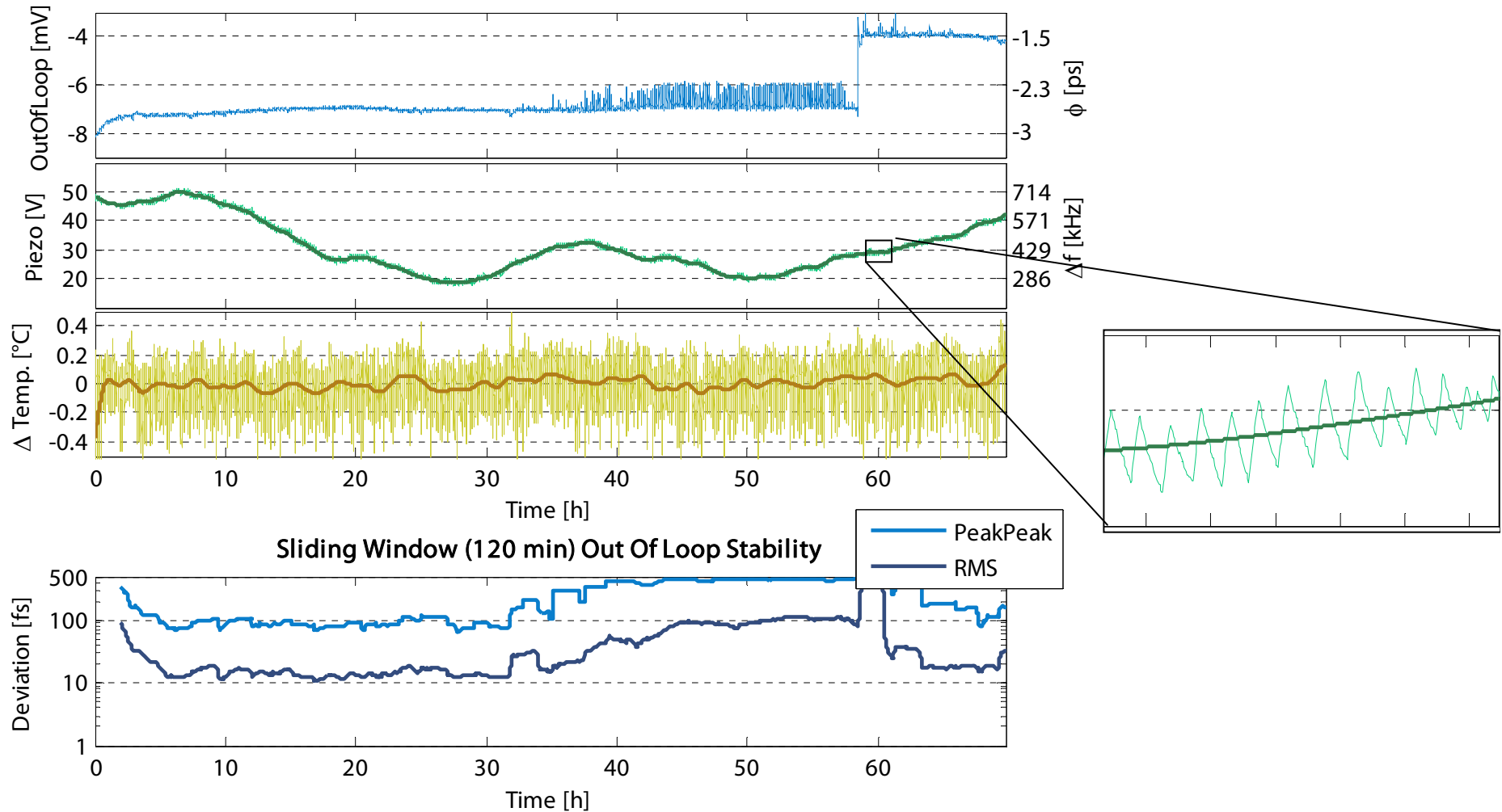

Sliding Window (120 min) Out Of Loop Stability

